



MXA910,, MXA910-60CM,,

MXA910W-A,, MXA910W-US

Ceiling Array Microphone

Shure MXA910 ceiling array microphone user guide. Includes mounting instructions, specifications, command strings, best practices, and microphone configuration details.

Version: 14 (2020-E)

Table of Contents

MXA910, MXA910-60CM, MXA910W-A, MXA910W-US-Ceiling Array Microphone	4	Rubber Scratch Protectors (MXA910 and MXA910-60CM)	1
NOTICE	4	Ceiling Installation (MXA910 and MXA910-60CM)	22
Overview	4	Rubber Scratch Protectors (MXA910W-A)	23
General Description	4	Ceiling Installation (MXA910W-A)	24
Features	5	Rubber Scratch Protectors (MXA910W-US)	26
System Overview	6	Ceiling Installation (MXA910W-US)	26
Differences Between 3.x and 4.x Firmware	7	Suspension Mounting	28
Getting Started	7	Cable Management	30
Step 1: Connect to a Network and Discover in Designer	8	Installing the Junction Box Accessory	31
Step 2: Route Audio and Apply DSP	8	Software Installation, Management, and Security	33
Step 3: Adjust Microphone Coverage	9	Controlling Devices with Shure Designer Software	33
System Planning and Gear Requirements	9	Accessing the Web Application	34
Overview of Shure Conferencing Devices	10	Firmware Updates	34
MXA910 Equipment Combinations	11	Microphone Configuration	35
Use Case: Soft Codec with ANIUSB or P300	12	Software Overview	35
Use Case: ANI22 and Hard Codec	13	Configuring Microphone Coverage for MXA910	36
Use Case: Medium or Large Room with 2 MXA910s and a P300	14	Using Autofocus to Improve Coverage	38
Hardware	14	Adjusting Levels	39
Network Ethernet Port	15	Parametric Equalizer (PEQ)	39
LED Light Bar	15	EQ Contours	42
Reset Button	17	Custom Presets	42
Power Over Ethernet (PoE)	17	Mute and Fader Groups	42
Installation	18	Encryption	43
Microphone Placement	18	Automix	43
FyreWrap® Fire Protective Wrap System Installation	20	Automix Channel	43
Installing the Array Microphone	21	Automix Modes	43
Model Variations	21	Automix Settings	44
		Automix Modes (Firmware <4.x only)	44
		IntelliMix DSP	45
		DSP Best Practices	45

Using Designer's Optimize Workflow	46	Manually Assigning Static IP Address	52
Acoustic Echo Cancellation	46	Setting Latency	52
Noise Reduction	47	Operating the Control Software over Wi-Fi	52
Automatic Gain Control (AGC)	47	Packet Bridge	53
Delay	48	IP Ports and Protocols	53
Compressor	48	Echo Reduction (Firmware <4.x only)	54
AES67	48	How It Works	55
Sending Audio from a Shure Device	49	Enabling Echo Reduction	55
Receiving Audio from a Device Using a Different Audio Network Protocol	49	Using a Third-Party Control System	55
Networking and Dante	49	Troubleshooting	56
Digital Audio Networking	49	Important Product Information	57
Switch Recommendations for Dante Networking	49	Information to the user	57
Compatibility with Dante Domain Manager	49	Specifications	57
Dante Flows for Shure Devices	50	Polar Response	60
Cable Requirements	50	Frequency Response	60
QoS (Quality of Service) Settings	50	Lobe Sensitivity	60
Networking Best Practices	51	Accessories	61
Network Audio and Shure Control Data	51	Optional Accessories and Replacement Parts	61
Device IP Settings	51	Furnished Accessories	62
Configuring IP Settings	52		

MXA910, MXA910-60CM, MXA910W-A, MXA910W-US Ceiling Array Microphone

NOTICE

Due to a preliminary finding by a federal court in the United States, Shure is authorized to ship the MXA910-60CM. This model is fully certified and lawful to use anywhere in the world but is not lawful to be used in the United States in a drop ceiling mounting configuration such as shown below. It is also unlawful to use adapters in an attempt to fit this smaller version to a ceiling grid within the United States such that it mounts substantially as shown below.



Furthermore, the MXA910-60CM is not designed or intended to be installed within a 24" ceiling grid, which is the standard size grid in North America. Mounting in such a grid in the above-shown configuration is unsafe and may cause damage to the product and/or injury to those below. The MXA910-60CM is safe and lawful for use in other mounting configurations, such as with hard ceilings, or suspended from a VESA pole or suspension wiring, anywhere in the world.

The MXA910W-US is now available for 24" ceiling grid installations in the United States. The MXA910W-US provides a quick, simple solution for installation in 24x24 inch ceiling grids in the U.S. and includes the same technology and performance as all prior versions. Though the MXA910W-US is designed for ceiling grid installation, it is not intended to be flush-mounted as shown above. For proper installation, see the Ceiling Installation (MXA910W-US) section below.

For more information or to place an order for the MXA910W-US, visit www.shure.com/mxa910.

Overview

General Description

The Microflex® Advance™ Ceiling Array is a premium networked array microphone for AV conferencing environments, including boardrooms, huddle rooms, and multi-purpose spaces. The ceiling array uses Shure's Steerable Coverage™ with Autofocus™ technology: 8 highly directional pickup lobes capture participant audio from overhead, continually fine-tuning the position of each lobe in real time as participants lean back in their chairs or stand up .

The microphone also includes the IntelliMix® DSP suite, which includes AEC, noise reduction, automatic mixing, and more. Control the microphone with Shure Designer software, or a browser-based web application. The microphone integrates seamlessly with Dante™ digital networked audio, AES67, and third-party preset controllers, including Crestron and AMX, to deliver a high-quality AV conferencing experience that appeals equally to integrators, consultants, and meeting participants.



Features

Configurable Coverage

- Steerable Coverage delivers precise pickup for up to 8 independent lobes
- Automatic lobe positioning speeds up installation
- Patent-pending Autofocus technology continually fine-tunes the position of each lobe in real time, for consistent sound when participants lean back in their chairs or stand up
 - Available on firmware 4.x and newer through a free update

IntelliMix DSP

- IntelliMix DSP provides automatic mixing, AEC, noise reduction, automatic gain control, delay, compressor, and channel equalization
- Available on firmware 4.x and newer through a free update

Software Control

- Shure Designer system configuration software provides comprehensive microphone and pattern control
- With Designer, you can also design coverage with online and offline devices, and route audio between Shure devices
- If Designer isn't available, use the browser-based web application to control the microphone
- Compatible with Shure SystemOn audio asset management software for remote monitoring and real-time alerts about critical issues

Network Connectivity

- Discrete audio channels for each lobe and an automix channel are delivered over a single network cable
- Dante digital audio coexists safely on the same network as IT and control data, or can be configured to use a dedicated network
- Control strings available for third-party preset controllers including Crestron and AMX

Professional Design

- Sleek industrial design blends with contemporary board rooms and meeting spaces
- Versatile mounting options for ceilings, pole mounts, suspension cables, and more
- Available in white, black, and aluminum finishes (detachable grille can be custom painted)

System Overview

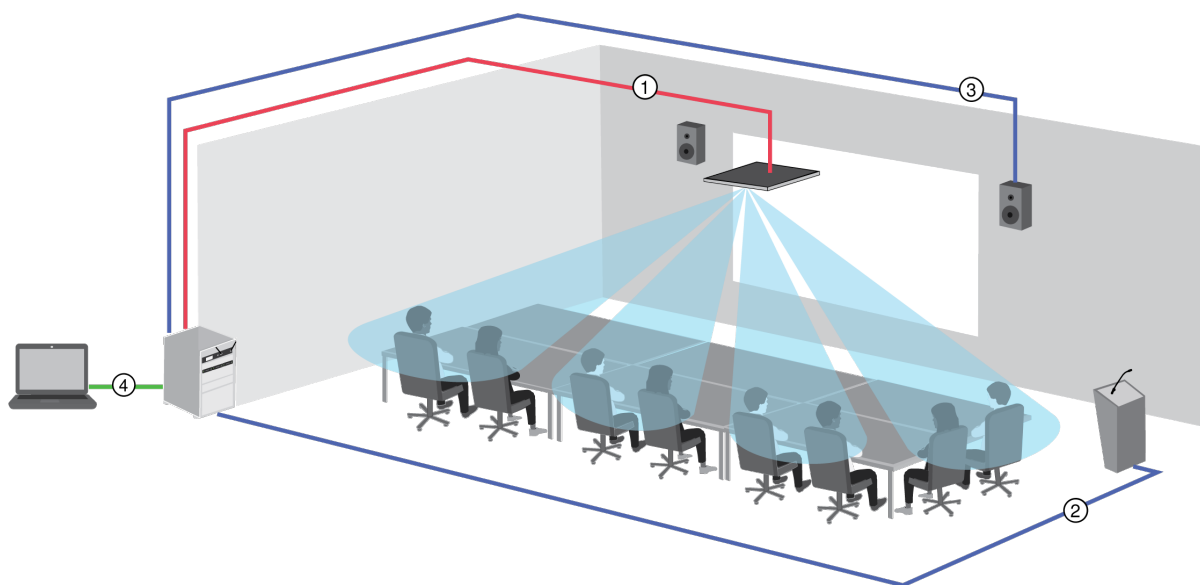

① Dante audio, power, and control

Each array microphone connects to the network over a single network cable, which carries Dante audio, Power over Ethernet (PoE), and control information to adjust coverage, audio levels, and processing.

② Analog audio (microphone to network)

Analog equipment, such as a wireless microphone system or a gooseneck microphone on a podium, connects to the Dante audio network through a Shure Network Interface (model ANI4IN) for a completely networked conferencing system.

③ Far-end audio (network to loudspeakers)

Dante-enabled loudspeakers and amplifiers connect directly to a network switch. Analog loudspeakers and amplifiers connect through a Shure Network Interface (model ANI4OUT), which converts Dante audio channels into analog signals, delivered through 4 discrete XLR or block connector outputs.

④ Device control and Dante audio

Control: A computer connected to the network controls the microphone with Shure Designer software. You can remotely adjust coverage, muting, LED behavior, lobe settings, gain, and network settings.

Audio: Route audio with Dante™ Controller or Shure Designer software. Dante Virtual Soundcard enables audio monitoring and recording directly on the computer.

Differences Between 3.x and 4.x Firmware

When you update an MXA910 from 3.x to 4.x firmware, you'll be able to use IntelliMix DSP features optimized for MXA.

Here's what changes with 4.x firmware:

IntelliMix DSP Added

- You can now use AGC, AEC, noise reduction, compressor, and delay.
 - These DSP features don't affect individual channel outputs—they only apply to the Automix Out channel
- If you're currently using the Automix Out channel on a 3.x device and you update it to 4.x, the following settings will be applied automatically:
 - AGC: enabled
 - AEC: enabled
 - Noise reduction: enabled
 - Compressor: disabled
 - Delay: disabled

New Automixer Added

- The 4.x automixer has different mix modes than the 3.x automixer.
- Here's how mix mode settings will change:

3.x Automixer Setting	New 4.x Automixer Setting
Classic	Gating
Smooth	Gain Sharing
Manual	Manual
Custom	Gating

New Autofocus Feature Added for All Lobes

- Patent-pending Autofocus™ technology continually fine-tunes the position of each lobe in real time.
- Lobes move automatically for consistent sound when participants lean back in their chairs or stand up.

Echo Reduction Removed

- The microphone now has AEC, so there's no need for echo reduction.
- The Echo Reduction Reference In channel's name in Dante Controller is now the "AEC Reference In" channel. Any existing Dante route to that channel will persist.

Other Changes

- Template 1's lobe positions have changed.
 - If you're using Template 1 with the default lobe positions, updating to 4.x will change your lobe positions.
- After updating, all custom lobe positions and Dante routes will stay the same.

Getting Started

To control the MXA910, use Shure Designer software to adjust microphone coverage, apply DSP, and route audio between Shure devices. After completing this basic setup process, you should be able to:

- Access and control the MXA910 in Designer
- Apply DSP to the microphone's signal
- Route audio from the microphone to other devices

Before you get started, you'll need:

- Cat5e (or better) Ethernet cable
- Network switch that provides Power over Ethernet (PoE)
- Shure Designer software installed on a computer. Download at www.shure.com.

Note: If Designer isn't available, you can use a web application to control the MXA910 and Dante Controller to route audio. Download the Shure Web Device Discovery application to access your device's web application.

Step 1: Connect to a Network and Discover in Designer

1. Connect the microphone to a PoE port on the network switch using Cat5e (or better) cable.
2. Connect your computer running Designer to the network switch.
3. Open Designer, and check that you're connected to the correct network in Settings.
4. Click Online devices. A list of online devices appears.
5. To identify devices, click the product icon to flash the lights on a device.

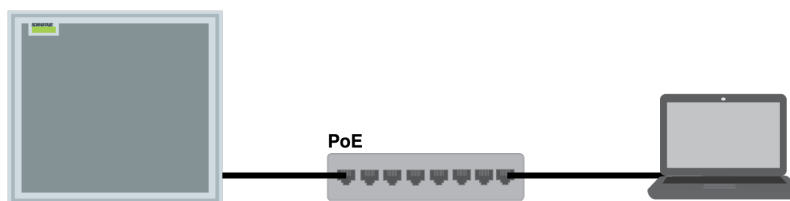

Step 2: Route Audio and Apply DSP

The easiest way to route audio and apply DSP is with Designer's Optimize workflow. Optimize automatically routes audio signals, applies DSP settings, turns on mute synchronization, and enables LED logic control for connected devices.

The MXA910 includes IntelliMix DSP that can be applied to the automix channel output.

For this example, we'll connect an MXA910 and an ANIUSB-MATRIX.

1. From My projects, select New to create a new project. Click New to add a location to your project.
2. Select Live mode. Any online devices appear in the list. Drag and drop the MXA910 and the ANIUSB-MATRIX to add them to your location.
3. Select Optimize.
4. Check the audio routes and settings to make sure they fit your needs. You might need to:
 - Delete unnecessary routes.
 - Verify that AEC reference signals are correctly routed.
 - Fine-tune DSP blocks as needed.

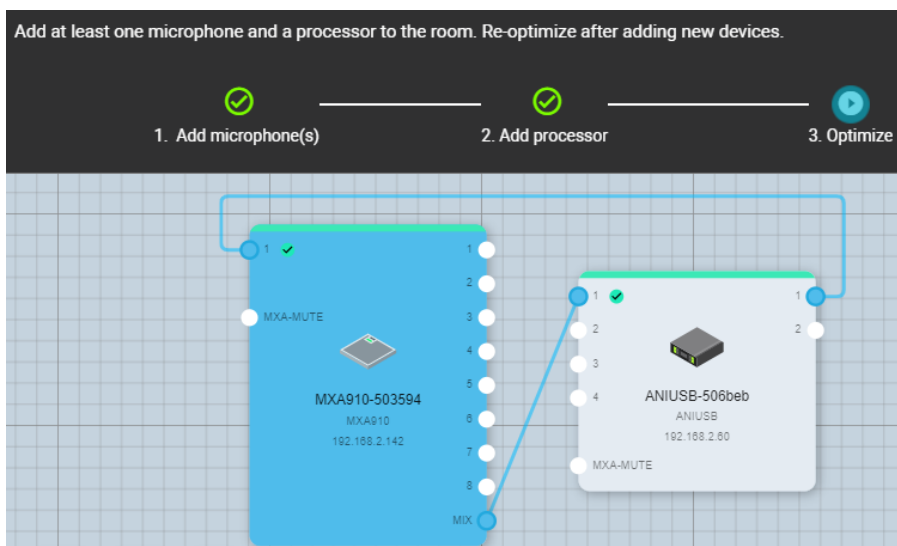

You can also route audio manually in Designer outside of the Optimize workflow, or use Dante Controller.

Step 3: Adjust Microphone Coverage

1. Select Coverage map to adjust the microphone's coverage.
2. Use Auto position to let the software position each channel for you.
3. Listen to each of your microphone's channels and adjust the lobe position, width, and gain as needed. Click and drag to adjust each channel's position. Learn more in the Configuring Microphone Coverage section.

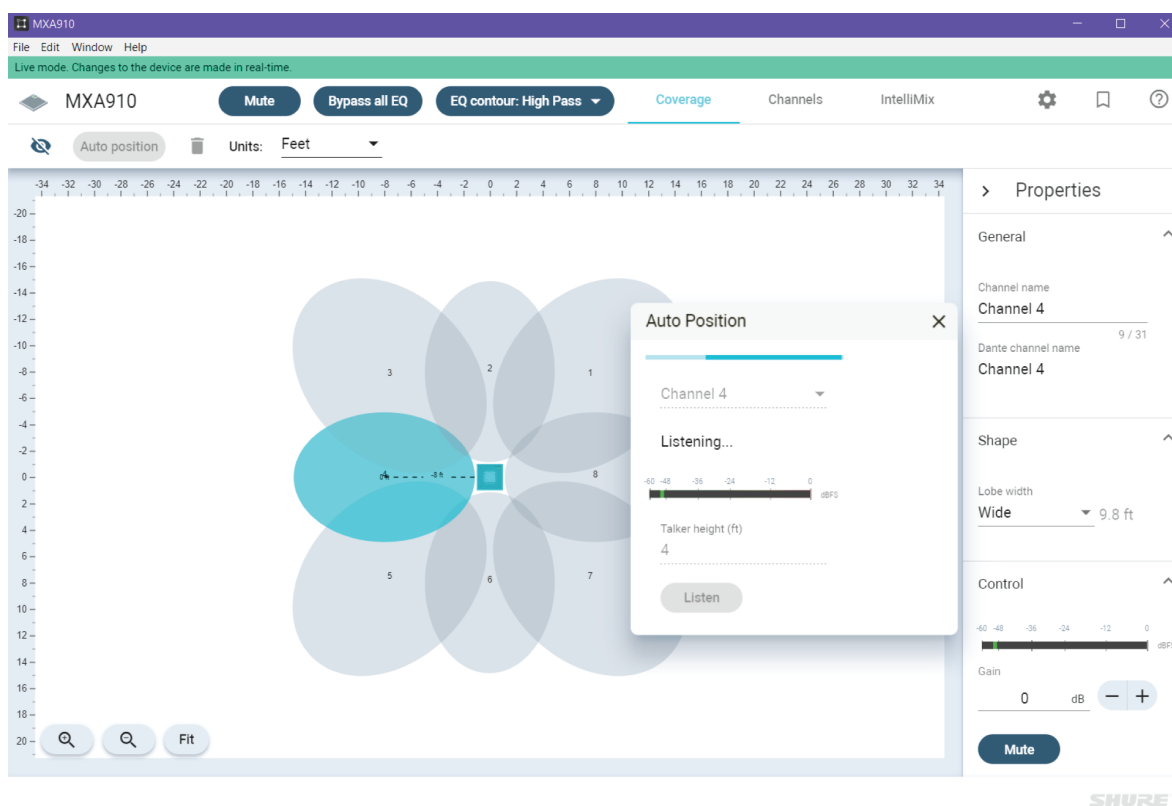







After you have coverage set up, you can send audio from the ANIUSB-MATRIX to other Dante devices or analog sources.

System Planning and Gear Requirements

Overview of Shure Conferencing Devices

Shure offers a range of connectivity options for conferencing. MXA microphones, audio processors, and network interfaces all use Dante to send audio over standard IT networks. You can use Shure's free [Designer software](#) to control most Shure devices and route audio between them.

Device	Purpose	Physical Connections	Dante I/Os
 MXA910	Ceiling array microphone with IntelliMix DSP	1 PoE port	8 individual channel outputs or 1 automix channel output with IntelliMix DSP 1 AEC reference input
 MXA710	Linear array microphone with IntelliMix DSP	1 PoE port	2 Foot: 4 individual channel outputs or 1 automix channel output with IntelliMix DSP 1 AEC reference input 4 Foot: 8 individual channel outputs or 1 automix channel output with IntelliMix DSP 1 AEC reference input
 MXA310	Table array microphone	1 PoE port	4 individual channel outputs or 1 automix channel output
 P300	Audio processor with IntelliMix DSP and matrix mixer	1 USB in/out 2 analog block in 2 analog block out 1 mobile TRRS port (3.5 mm) 1 PoE+ port	8 Dante inputs with IntelliMix DSP 2 auxiliary Dante inputs 8 Dante outputs
 IntelliMix Room	Audio processing software with IntelliMix DSP and matrix mixer	Varies depending on device	8 or 16 Dante inputs with IntelliMix DSP 8 auxiliary Dante inputs 8 Dante outputs 1 virtual audio input and output 1 PC input and output
	Matrix mixer with USB and analog input/output	1 USB in/out	4 Dante inputs

Device	Purpose	Physical Connections	Dante I/Os
ANIUSB-MATRIX		1 analog block in 1 analog block out 1 PoE port	2 Dante outputs
 ANI4IN (block or XLR connectors)	Converts analog signals to Dante signals	4 analog in 1 PoE port	4 Dante inputs
 ANI4OUT (block or XLR connectors)	Converts Dante signals to analog signals	4 analog out 1 PoE port	4 Dante outputs
 ANI22 (block or XLR connectors)	Converts 2 analog signals to Dante signals Converts 2 Dante signals to analog signals	2 analog in 2 analog out 1 PoE port	2 Dante inputs 2 Dante outputs
 MXN5-C	Networked ceiling loudspeaker powered by PoE	1 PoE port	2 Dante inputs 1 Dante output
 MXA Network Mute Button	PoE-powered network mute button for Shure devices	1 PoE port 1 power cable connector for base	n/a

MXA910 Equipment Combinations

	MXA910 and ANI22	MXA910 and ANIUSB	MXA910 and P300
Room size	Small or medium	Small or medium	Medium or large
Mobile I/O	No	No	Yes
Analog I/O	2x2	1x1	2x2
USB I/O	No	Yes	Yes
Power	PoE	PoE	PoE+
Logic control	No	No	Yes
Soft codec mute sync	No	Yes	Yes with P300 firmware 3.1.5 or later
Accommodates multiple MXA910s	No	No	Yes
Accommodates additional analog mics	No	No	Yes

For more analog inputs, use ANI4INs to convert analog signals to Dante signals. For more analog outputs, use ANI4OUTs to convert Dante signals to analog signals.

Use Case: Soft Codec with ANIUSB or P300

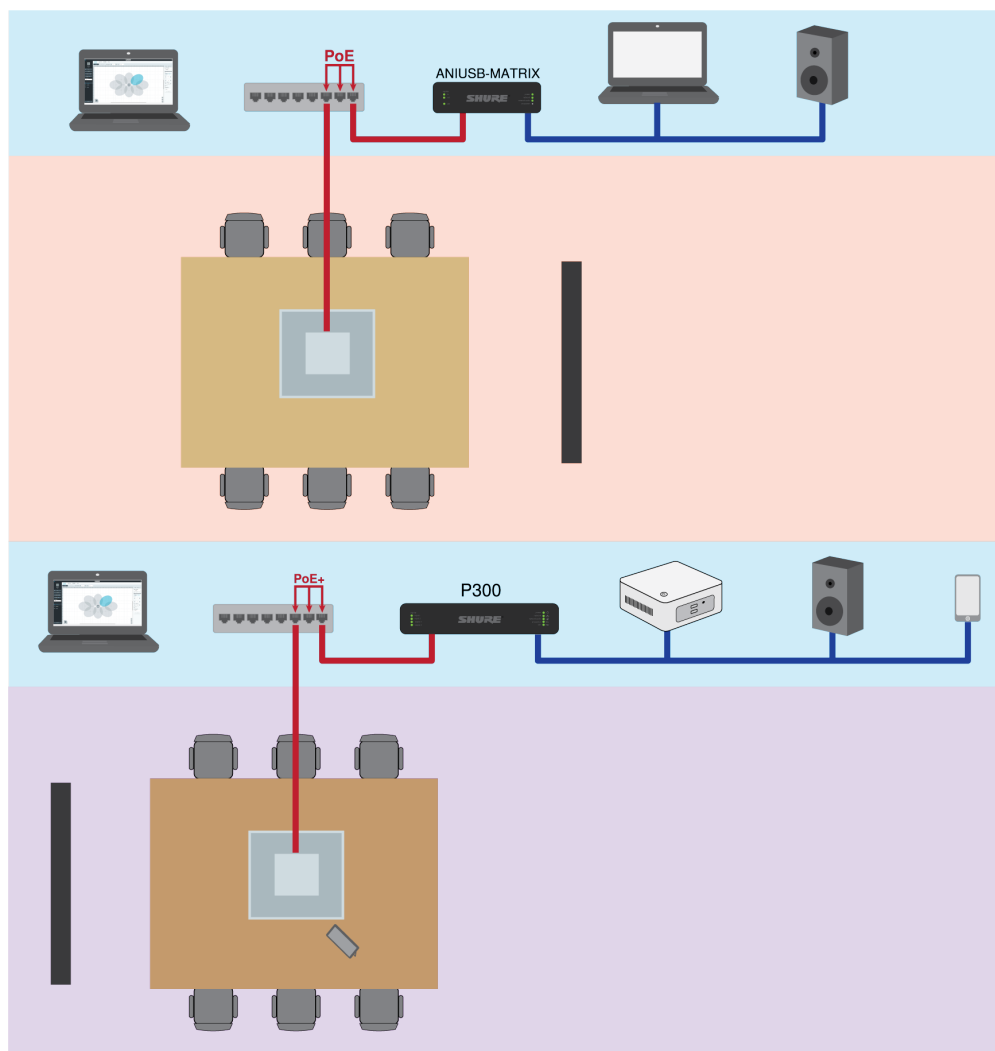

For an easy soft codec solution, use the ceiling array with an ANIUSB-MATRIX or a P300.

- Computer running conferencing software connects to the ANIUSB-MATRIX or P300 with a USB cable
- Ceiling array provides acoustic echo cancellation and DSP (with firmware >4.x)
- Matrix mixer in ANIUSB-MATRIX or P300 routes signals to any connected device
- P300 has soft codec mute sync for USB connections with firmware >3.1.5

Equipment List:

- MXA910 (needs firmware >4.x for AEC)
- ANIUSB-MATRIX or P300
- Computer with conferencing software
- Network switch supplying Power over Ethernet (PoE)
- Computer on network with:
 - Shure Designer software **or**
 - Device web applications

- Cat5e (or better) Ethernet cables
- USB cable
- Control panel for P300 soft codec mute sync
- Any other speakers, amplifiers, or displays

Use Case: ANI22 and Hard Codec

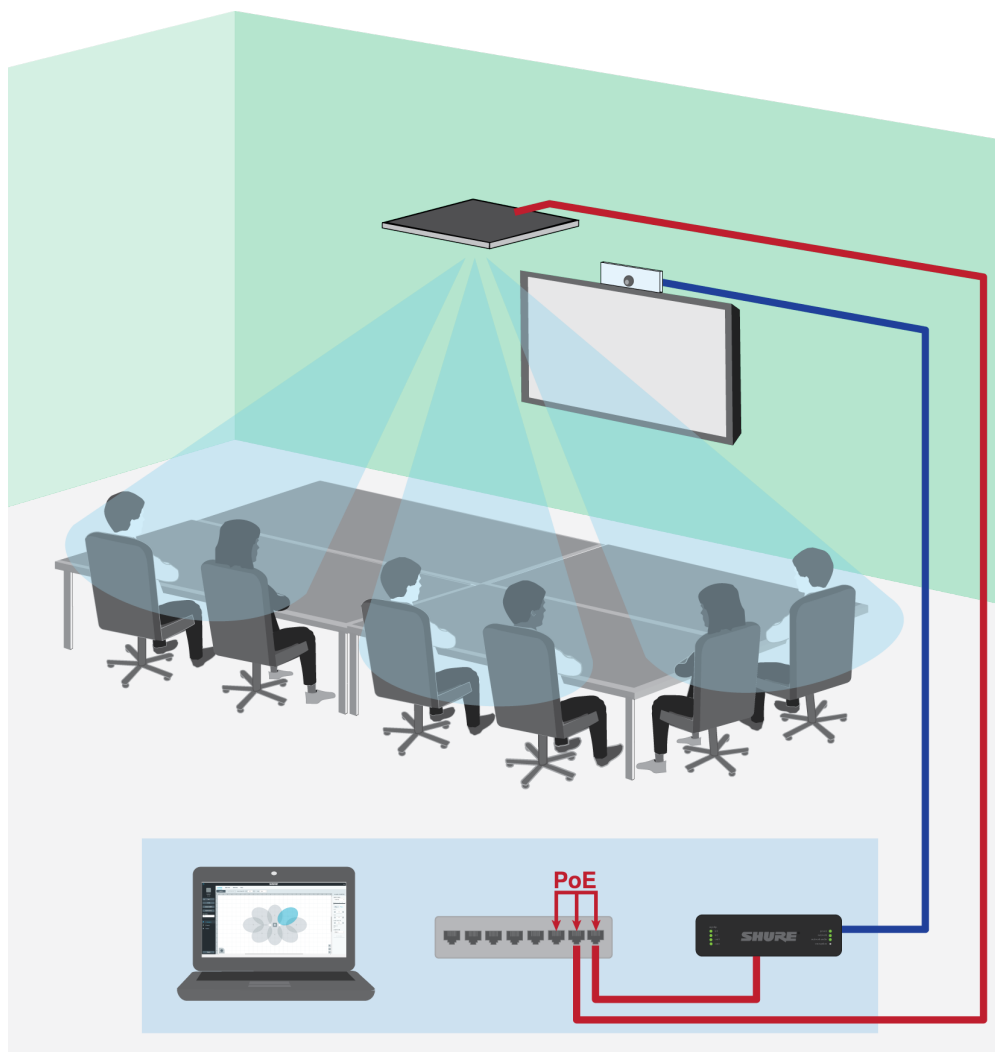

- Hard codec connects room to far-end callers
- Ceiling array provides acoustic echo cancellation and DSP (with firmware >4.x)
- ANI22 connects analog and digital components
 - 2 line/mic inputs convert analog signals to digital
 - 2 outputs to convert digital signals to analog

Equipment List:

- MXA910 (needs firmware >4.x for AEC)
- ANI22 (block or XLR connector versions available)
- Hard codec
- Display
- Network switch supplying Power over Ethernet (PoE)

- Computer on network with:
 - Shure Designer software **or**
 - Device web applications
- Cat5e (or better) Ethernet cables
- Analog block or XLR cables to connect components to ANI22
- Any other speakers or amplifiers

Use Case: Medium or Large Room with 2 MXA910s and a P300

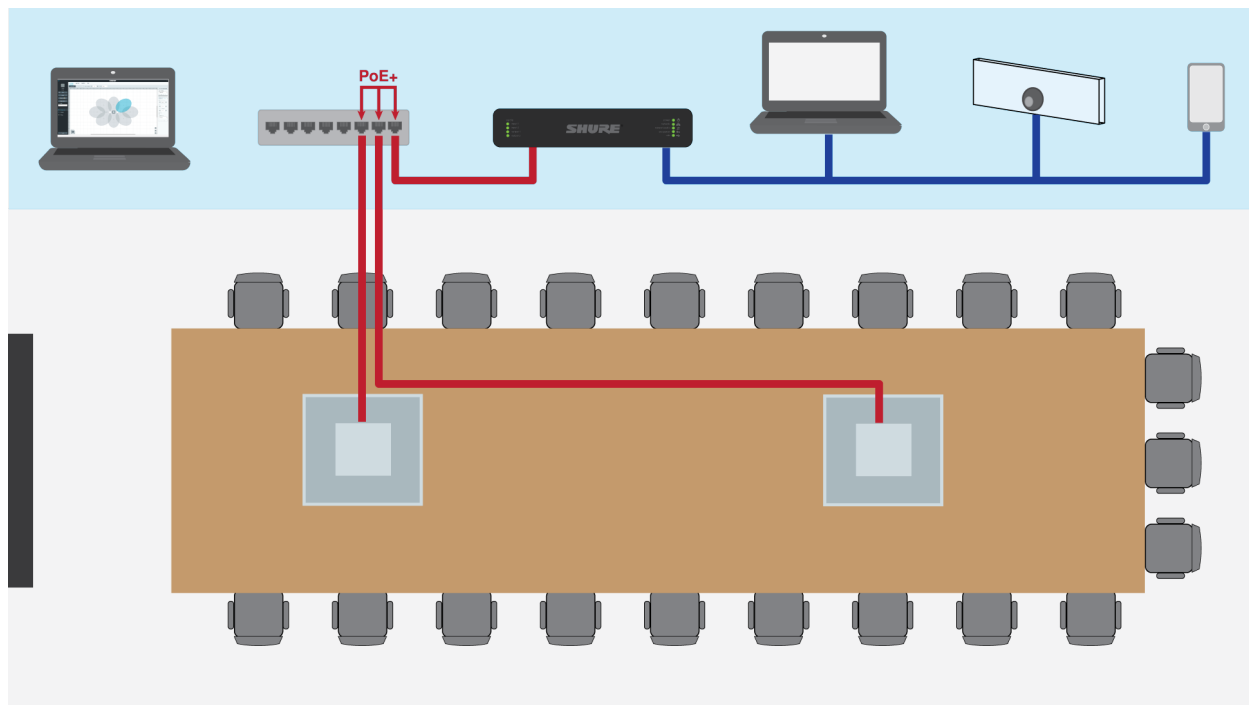

In larger installations, you can use multiple MXA910s and a P300 for a distributed DSP approach that makes installation simpler. For best results, use a maximum of 3 MXA910s.

- Ceiling arrays handle DSP (with firmware >4.x)
- P300 provides matrix mixer and connection options for mobile devices, USB, and analog block in/out
- Designer controls microphones and P300

Equipment List:

- 2 MXA910s (needs firmware >4.x for AEC)
- P300
- Network switch supplying Power over Ethernet Plus (PoE+)
- Computer on network with:
 - Shure Designer software **or**
 - Device web applications
- Cat5e (or better) Ethernet cables
- Any other speakers, mobile devices, codecs, or displays

Hardware

Network Ethernet Port

The network port carries all audio, power, and control data. It is located on the back panel as shown.

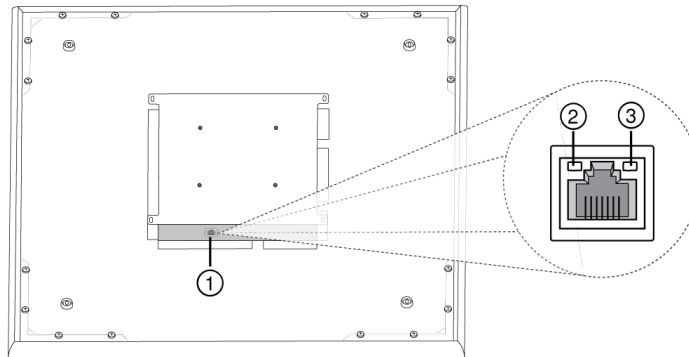

① Network Port

RJ-45 jack for network connection.

② Network Status LED (Green)

Off = no network link

On = network link established

Flashing = network link active

③ Network Speed LED (Amber)

Off = 10/100 Mbps

On = 1 Gbps

LED Light Bar

The LED on the microphone indicates whether the microphone is active or muted, identifies the hardware, and provides confirmation of firmware updates.

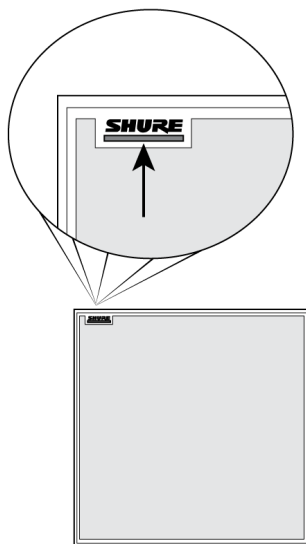

Default Settings

Microphone Status	LED Behavior / Color
Active	Green (solid)
Mute	Red (solid)
Hardware identification	Green (flashing)
Firmware update in progress	Green (progresses along bar)
Reset	Network reset: Red (progresses along bar) Factory reset: Triggers device power-up
Error	Red (split, alternate flashing)
Device power-up	Multi-color flash, Blue (moves quickly back and forth across bar)

Note: When the LED is disabled, the LED still illuminates while the device is powering up and when an error state occurs.

Customizing Lighting Settings

Custom LED brightness, colors, and behaviors are assignable in the control software. They can also be controlled through an external control system:

1. Open the Configuration tab
2. Select Light Bar

Mute LED Behavior

The lighting for mute and active microphone states is configurable to match the behavior of other devices in conference rooms. In the LIGHT BAR PROPERTIES menu, use the drop-down menus to select LED settings.

Dimming and Disabling

To dim or turn off the LED, use the brightness fader.

Reset Button

The hardware reset button is located inside a grille hole and can be pushed with a paperclip or other small tool. The hole is identified with a gray circle. When looking at the Shure logo, it is the second hole in the fourth row from the top.

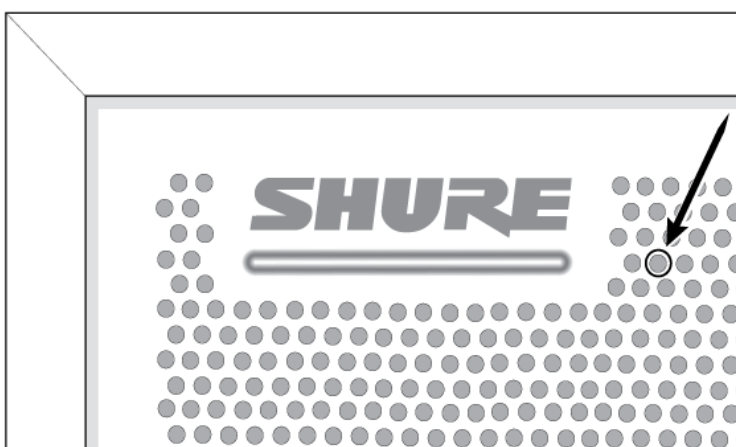

Reset Modes

Network reset (press button for 4-8 seconds)

Resets all Shure control and audio network IP settings to factory defaults.

Full factory reset (press button for longer than 8 seconds)

Restores all network and web application settings to the factory defaults.

Software Reset Options

To simply revert settings without a complete hardware reset, use one of the following options:

Reboot Device (Settings > Factory Reset): Power-cycles the device as if it were unplugged from the network. All settings are retained when the device is rebooted.

Default Settings (Presets > Load Preset > Default Settings): Reverts audio settings back to the factory configuration (excluding Device Name, IP Settings, and Passwords).



If you're using Shure Designer software to configure your system, please check the Designer help section for more about this topic.

Power Over Ethernet (PoE)

This device requires PoE to operate. It is compatible with both **Class 0** and **Class 3** PoE sources.

Power over Ethernet is delivered in one of the following ways:

- A network switch that provides PoE
- A PoE injector device

Installation

Microphone Placement

Room Variables

Optimal microphone placement is determined by the seating arrangements and infrastructure. Follow these guidelines for the best possible results:

- In rooms with flexible furniture arrangements or multiple array microphones, use the microphone configuration tool in the web application or Shure Designer software to ensure that the coverage is adequate for all seating scenarios.
- The lobes should be pointed towards the front of each talker. Carefully consider placement in rooms where talkers may face a screen during a video conference.
- Avoid installing the microphone directly next to unwanted sound sources, such as air vents or noisy video projectors.
- Consider installing acoustic treatment to improve speech intelligibility in rooms that are too reverberant.

Mounting Height

The maximum mounting height that can be set is 30 feet (9.14 meters). In a typical acoustic environment¹, the microphone maintains an "A" rating based on the STIPA² (Speech Transmission Index for Public Address systems) international standard at distances up to 16 feet between the microphone and talker. In better acoustic environments, the STIPA "A" rating may extend beyond 16 feet.

Consider the following when determining a mounting height:

- The pickup pattern of the ceiling array is narrower than a shotgun microphone, and therefore it can be placed farther from the source than any other microphone. While the web application shows an ideal coverage zone for each channel, keep in mind that there is no specific barrier at which the audio degrades or gates off. Lobe sensitivity data is available for each width setting in the product specifications.
- Like all microphones, tonality changes as the distance from the source increases.
- The intelligibility scale helps to predict how the microphone will sound at a given height.
- The coverage area of the lobes increases at farther distances.

[1] Room conditions: RT60 (reverb time) = 500 ms @ 1kHz, A weighted room noise = 40dB SPL(A)

[2] IEC-602682-16 standard

Intelligibility Scale

The intelligibility scale objectively compares the acoustic performance of the array microphone with a cardioid gooseneck microphone at various distances. This information is useful for predicting how the array microphone will perform at a given distance and to determine an ideal mounting height. The data in the intelligibility scale table is derived from measuring the microphones to meet an equivalent value from the **Speech Transmission Index IEC-602682-16 standard**.

Distances With Equivalent Speech Transmission Index Values

Ceiling Array Microphone (Distance to Talker)	Cardioid Gooseneck Microphone (Distance to Talker)
6 ft (1.83 m)	3.75 feet (1.14 m)
8 ft (2.44 m)	5 feet (1.52 m)
10 ft (3.05 m)	6.25 feet (1.91 m)
12 ft (3.66 m)	7.5 feet (2.29 m)

Data was collected in a typical huddle room with the following measurements:

- **Reverberation decay time:** 500 ms @ 1kHz
- **Noise floor:** 40 dB SPL (A-weighted)

Note: These values are specific to the described room. In a well-controlled acoustic environment, the array microphone may perform with equivalent Speech Transmission Index values at even greater distances. In highly reverberant rooms, the performance is less predictable.

A = Distance between array microphone and talker

B = Distance between cardioid microphone and talker



In this example, the acoustic performance of the array microphone mounted (A) feet from the talker matches the cardioid gooseneck microphone placed at a distance of (B) feet from the talker.

FyreWrap[®] Fire Protective Wrap System Installation

The FyreWrap fire protective wrap system included with the MicroflexAdvance MXA910 ceiling array microphone must be installed to meet the UL 2043 plenum rating (suitable for air handling spaces).

Installation

1. Make sure the microphone surface is clean to ensure proper adhesion
2. Remove the paper backing from the 4 adhesive pads on the fire wrap system
3. Align the fire wrap system over the microphone and secure it by applying gentle pressure over the adhesive pads

Note: make sure to leave enough space to install the Ethernet cable and safety tether (if required).

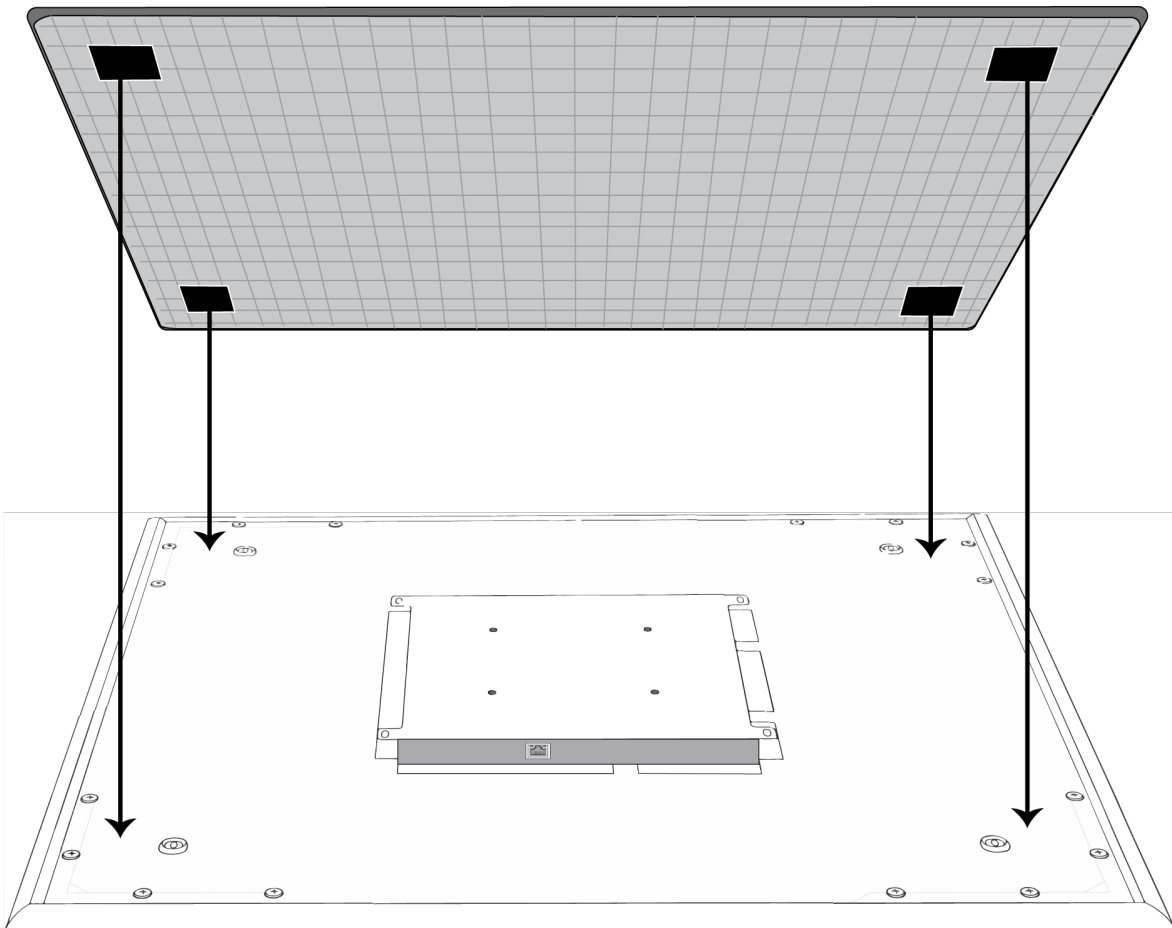

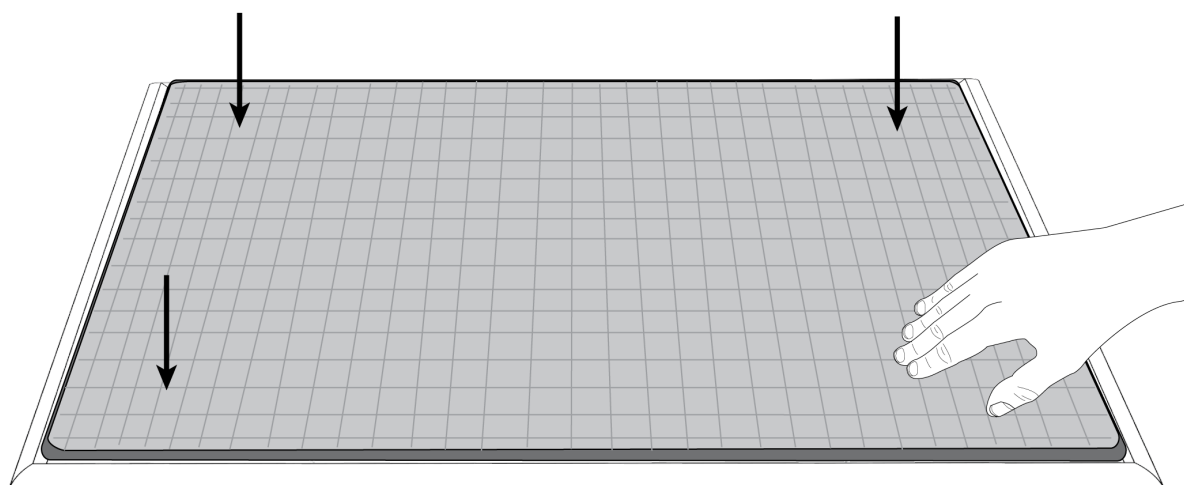

Installing the Array Microphone

The array microphone mounts directly in a ceiling grid, or can be attached using other methods.

Before you begin:

- Remove the protective plastic cover from the microphone.
- Verify the ceiling grid size matches the appropriate model variation.
- If using the optional junction box, install it on the microphone prior to ceiling installation.

IMPORTANT: Do not install the 60 cm model in a 2 ft (609.6 mm) ceiling grid.

Model Variations

Model	Ceiling Grid Size	Color
MXA910B	2 x 2 ft (60.9 x 60.9 cm)	Black
MXA910W	2 x 2 ft (60.9 x 60.9 cm)	White
MXA910AL	2 x 2 ft (60.9 x 60.9 cm)	Aluminum
MXA910B-60CM	60 x 60 cm (23.6 x 23.6 in)	Black
MXA910W-60CM	60 x 60 cm (23.6 x 23.6 in)	White
MXA910AL-60CM	60 x 60 cm (23.6 x 23.6 in)	Aluminum
MXA910W-A	2 x 2 ft (60.9 x 60.9 cm)	White
MXA910W-US	2 x 2 ft (60.9 x 60.9 cm)	White

Rubber Scratch Protectors (MXA910 and MXA910-60CM)

Optional: Before installing the microphone in the ceiling, attach the included rubber pads on the corners of the microphone to prevent scratching.

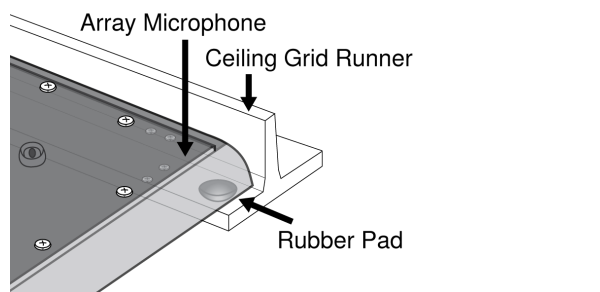

Ceiling Installation (MXA910 and MXA910-60CM)

1. Make space in the ceiling grid for the array microphone to be installed.
2. Run the Ethernet cable above the ceiling grid and through the opening in the ceiling.

Note: An optional junction box accessory (model A910-JB) mounts on the microphone to directly connect conduit.

3. Plug the Ethernet cable into the array microphone output.
4. Attach the safety tether between the building structure and one of the tie-off points on the back of the microphone using braided metal cable or other high-strength wire (not included). This safety measure prevents the microphone from falling in an emergency situation. Make sure there is no tension on the safety tether. Follow any local regulations.
5. Install the microphone into the ceiling grid.

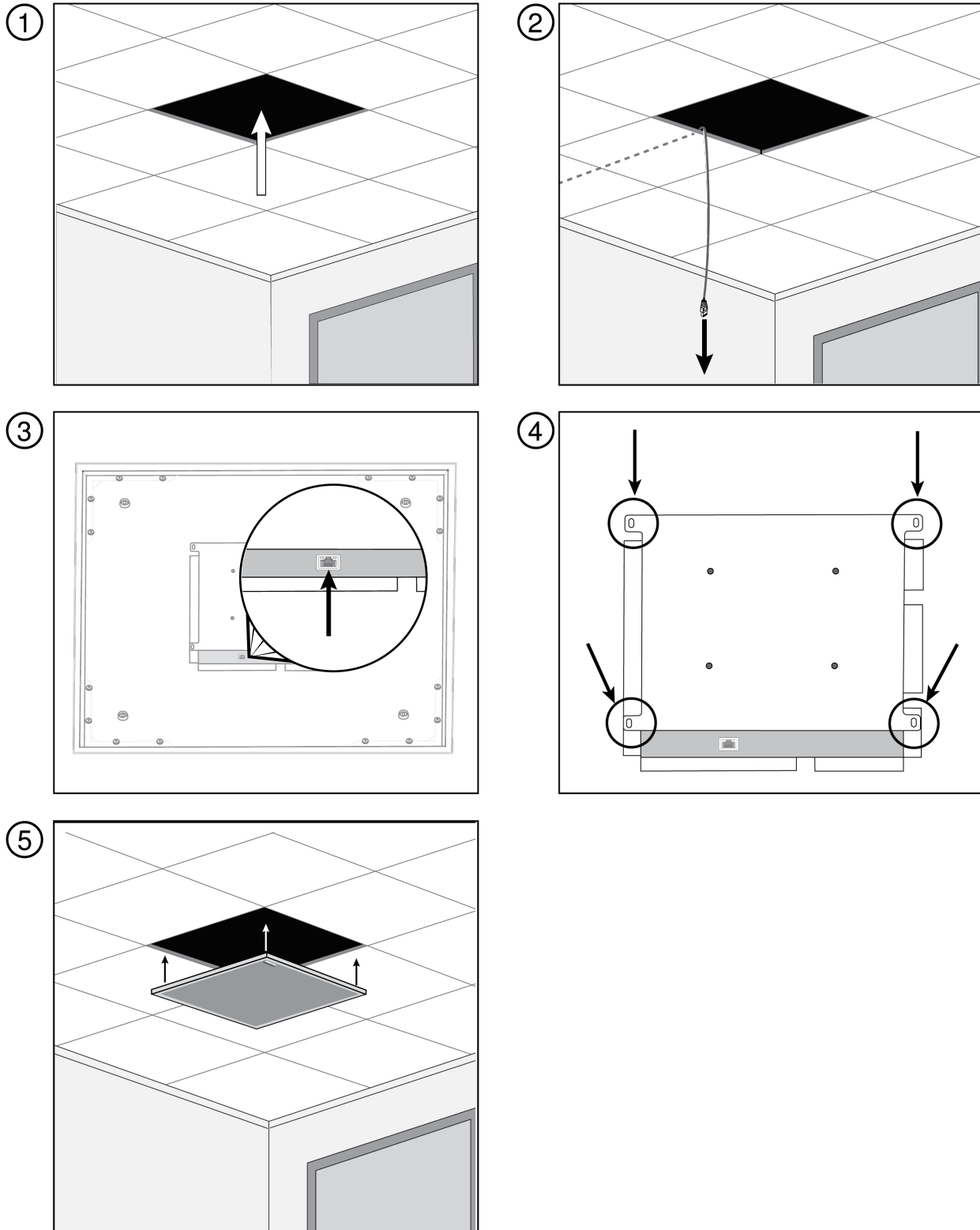

Rubber Scratch Protectors (MXA910W-A)

Optional: Before installing the microphone in the ceiling, attach the included rubber pads to the corners of the microphone flange to prevent scratching.

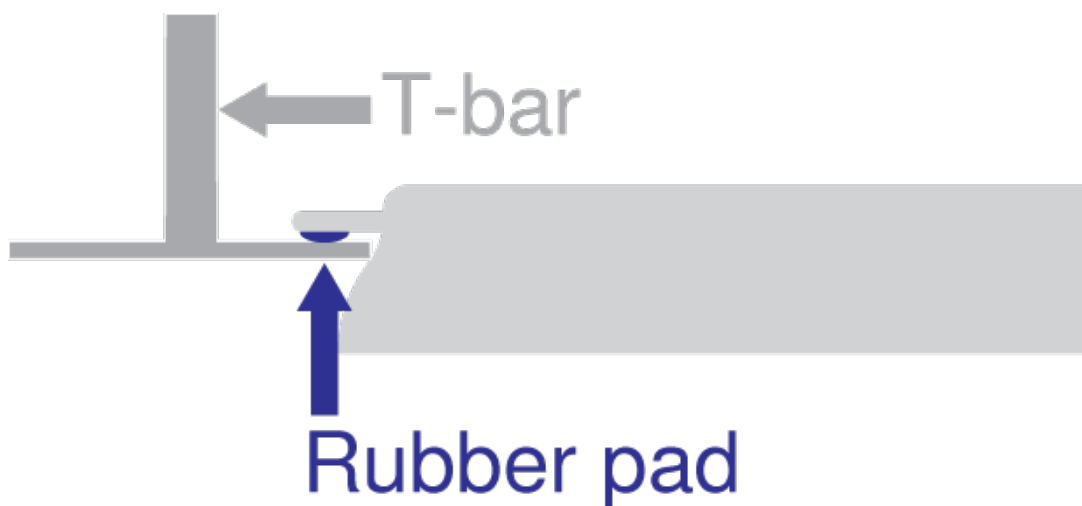

Ceiling Installation (MXA910W-A)

1. Make space in the ceiling grid for the array microphone to be installed.
2. Run the Ethernet cable above the ceiling grid and through the opening in the ceiling.

Note: An optional junction box accessory (model A910-JB) mounts on the microphone to directly connect conduit.

3. Plug the Ethernet cable into the array microphone output.
4. Attach the safety tether between the building structure and one of the tie-off points on the back of the microphone using braided metal cable or other high-strength wire (not included). This safety measure prevents the microphone from falling in an emergency situation. Make sure there is no tension on the safety tether. Follow any local regulations.
5. Install the microphone in the ceiling grid. The flange sits on the ceiling grid, and the microphone hangs below it.

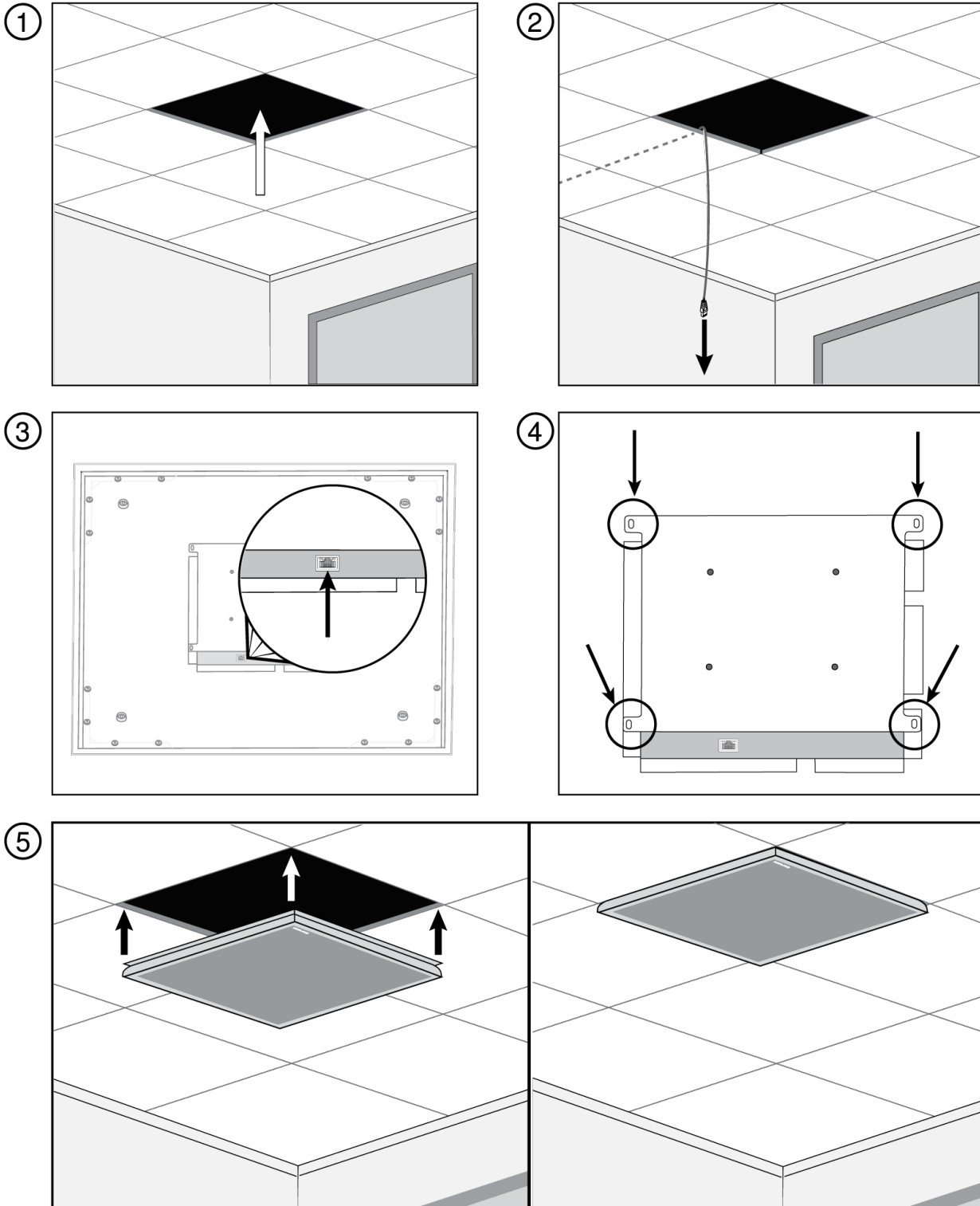

Note: Depending on the width of the ceiling grid T-bars, you may need to remove or adjust one side's T-bar to install the MXA910W-A.

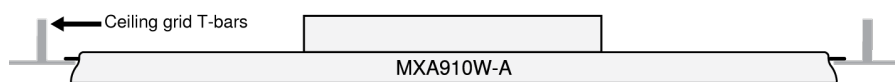

Rubber Scratch Protectors (MXA910W-US)

Optional: Before installing the microphone in the ceiling, attach the included rubber pads to the corners of the microphone flange to prevent scratching.

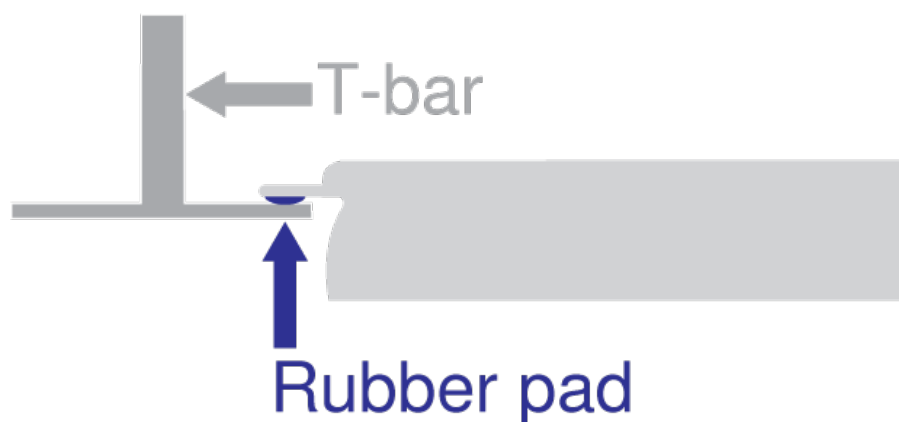

Ceiling Installation (MXA910W-US)

1. Make space in the ceiling grid for the array microphone to be installed.
2. Run the Ethernet cable above the ceiling grid and through the opening in the ceiling.

Note: An optional junction box accessory (model A910-JB) mounts on the microphone to directly connect conduit.

3. Plug the Ethernet cable into the array microphone output.
4. Attach the safety tether between the building structure and one of the tie-off points on the back of the microphone using braided metal cable or other high-strength wire (not included). This safety measure prevents the microphone from falling in an emergency situation. Make sure there is no tension on the safety tether. Follow any local regulations.
5. Install the microphone in the ceiling grid. The flange sits on the ceiling grid, and the microphone hangs below it.

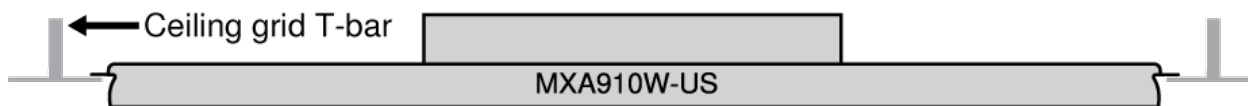
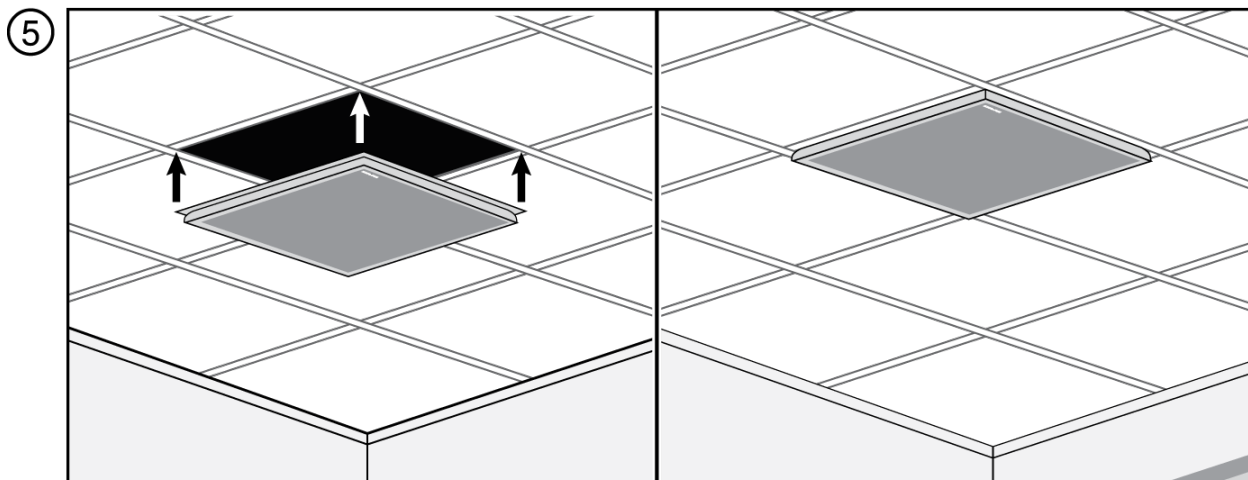
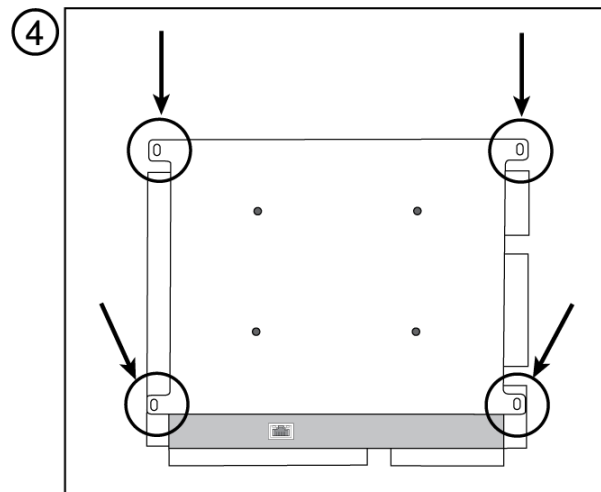
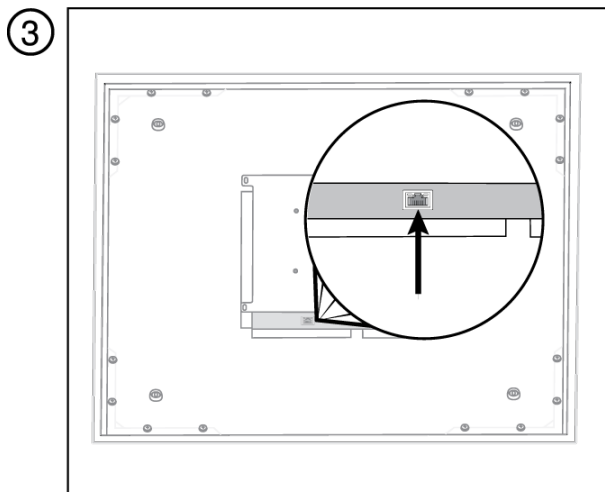
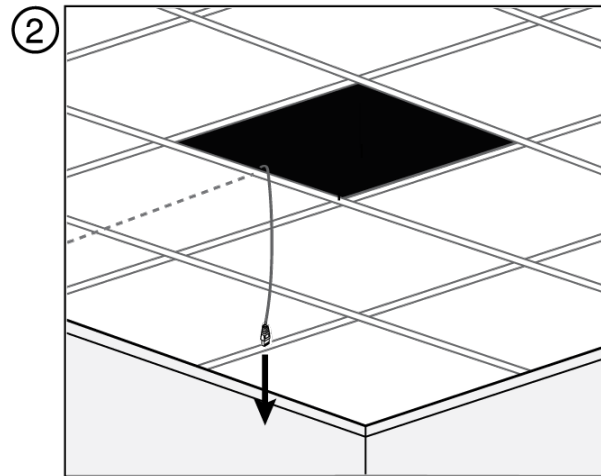
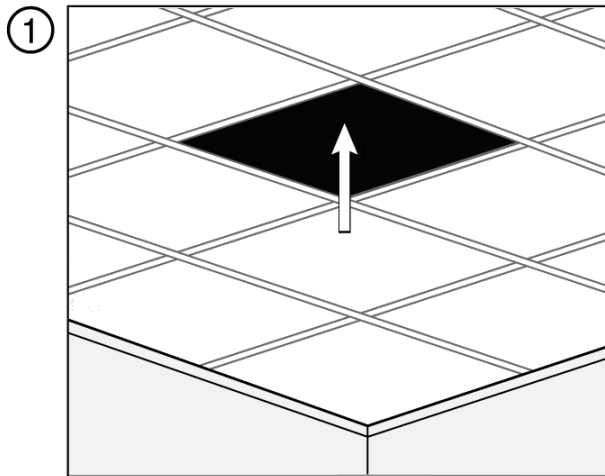

Suspension Mounting

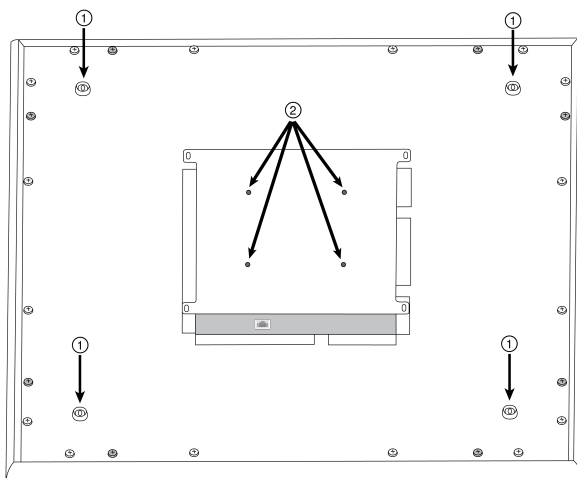

- ① Wire Suspension Hanging Points (4 mm hole size)
- ② VESA Mounting Holes

4-Point Wire Suspension

Secure the microphone to the ceiling using braided metal cable or other high-strength wire. Use the 4 integrated hanging points on the back of the microphone to securely attach the cable. The hole size in the hanging points is 4 mm (0.15 in).

VESA Standardized Mounting

The rear plate on the microphone has 4 threaded holes for attaching the microphone to a VESA mounting device. The mounting holes follow the VESA MIS-D standard:

- Screw specification: M4 thread (Microphone threaded hole depth = 9.15 mm)
- Hole spacing: 100 mm (square)

Hard Ceiling Mounting

You can mount the microphone in hard ceilings without a tile grid using the A910-HCM accessory.

Learn more at www.shure.com.

Painting Components

The grille and frame of the array microphone can be painted to blend in with room design. Some basic disassembly is required for painting.

Step 1: Removing the Frame and Grille

1. Remove the screws that hold the main assembly on the frame (6 screws per side). There are washers between these screws and the rear panel.

Important: Do not remove the screws that are farthest in the corner and recessed into the panel (see graphic).

2. Carefully lift the assembly out of the frame.
3. Remove the gray plastic LED lightpipe. Leave the black plastic guide in place.
4. Remove all 4 screws from one side of the frame (see image).
5. Remove the side of the frame.
6. Slide the flat grille out of the frame for easy removal of the foam piece.
7. Carefully remove the foam piece from the grille. Pull from the edges, where it is attached with hook and loop fastener strips.

Important: Do not paint the foam.

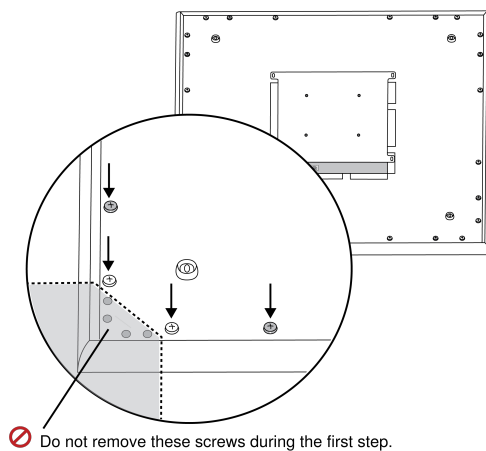

(1.1) Removing the screws to detach the main assembly

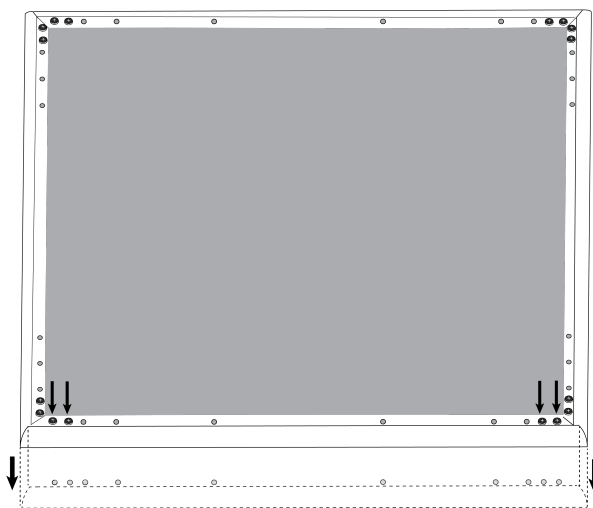

(1.4 - 1.5) Removing screws and detaching one side of the frame

Step 2: Masking and Painting

1. Use masking tape to cover the entire extrusion that runs along the inside of the frame. This ensures that the necessary metal pieces make contact when reassembled.
2. Use masking tape to cover the hook-and-loop fastener strips on the grille.

3. Paint the frame and grille section and allow it to completely dry before reassembling. Do not paint any part of the main assembly.

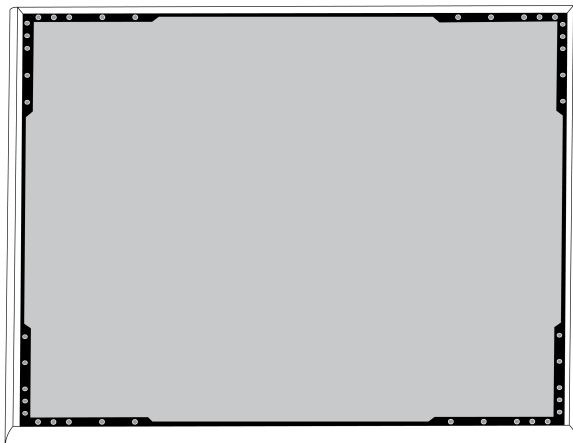

(2.1) Masking off the extrusion (highlighted in black)

Step 3: Reassembly

1. Secure the foam piece with the hook-and-loop fastener strips around the edges.
2. Slide the grille back into the frame.
3. Attach the remaining side of the frame and secure it with the 4 screws.
4. Attach the LED lightpipe into the black plastic guide piece.
5. Align the LED with the lightpipe and put the assembly back in place on the frame.

Note: The label on the assembly is placed on the corner that corresponds to the LED. Use it for reference to ensure proper orientation during re-assembly.

6. Install the screws (6 per side) to secure the main assembly to the frame. Do not over-tighten.

Cable Management

To keep the Ethernet cable out of view, use the appropriate method based on the installation type.

Installation	Cable Solution
Ceiling grid	Run the cable above the ceiling grid
VESA (pole mounting)	Guide the cable through the pole to run it above the ceiling grid
4-point wire suspension	Use cable ties to attach the CAT5 cable along one of the hanging wires
Hard ceiling	Run the cable above the ceiling

Note: If using conduit to contain the cable, the optional junction box accessory (model A910-JB) mounts directly to the rear panel of the microphone.

Note: For ceiling grid installations, see the Notice or visit <https://shu.re/QandA>.

Installing the Junction Box Accessory

The A910-JB junction box mounts on the microphone, enabling conduit connections for cable runs. Refer to local building codes and regulations to determine if the junction box is necessary. There are three punch-out sections on the junction box for attaching conduit.

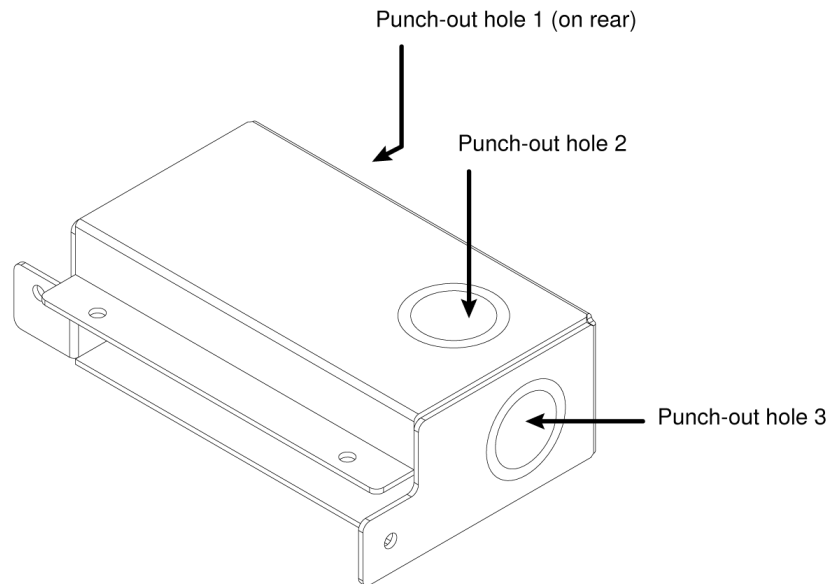

Important: Punch out the necessary holes in the junction box prior to installing it onto the microphone.

To install:

1. Remove the 4 screws from the microphone as shown.
2. Align the junction box with the screw holes. If possible, plug the network cable into the microphone before securing the junction box.

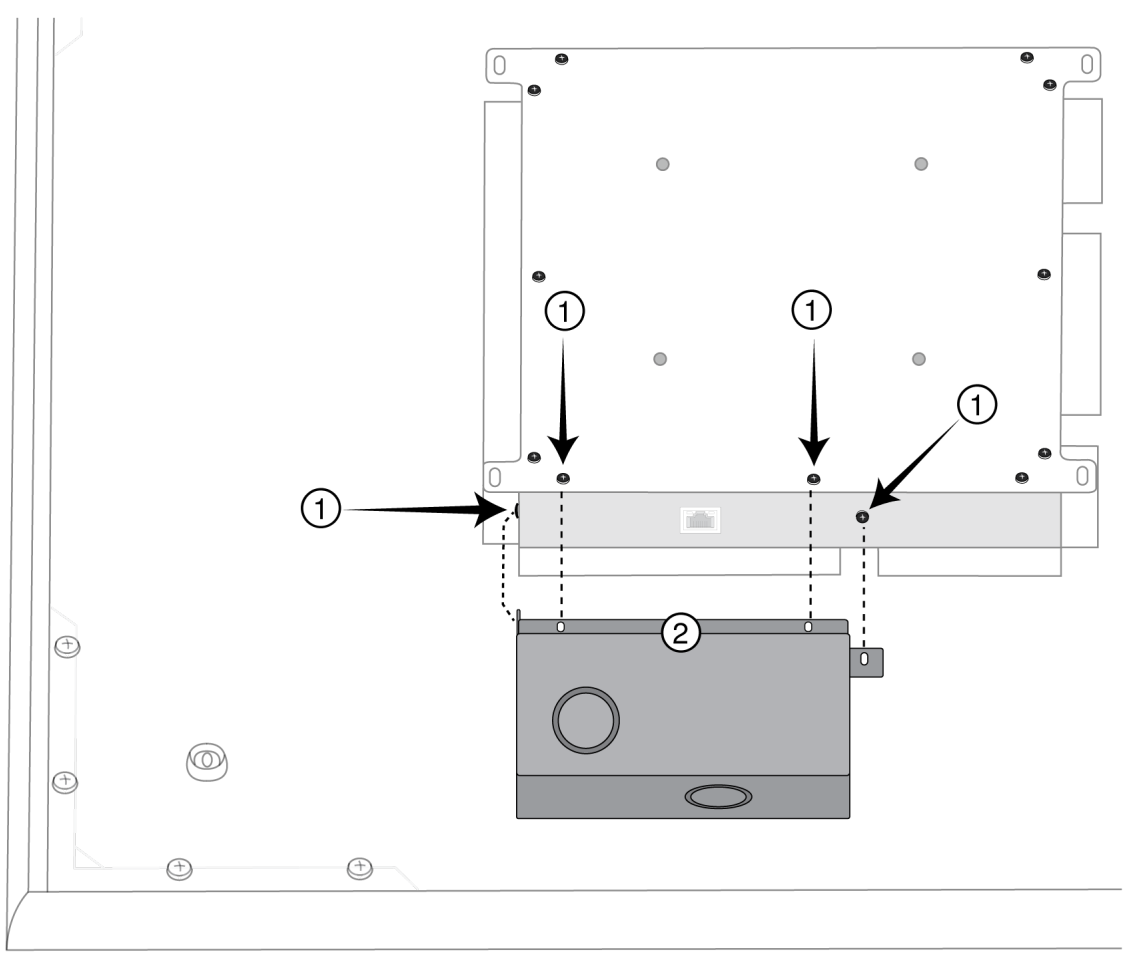

3. Install the 4 screws to secure the junction box on the microphone.

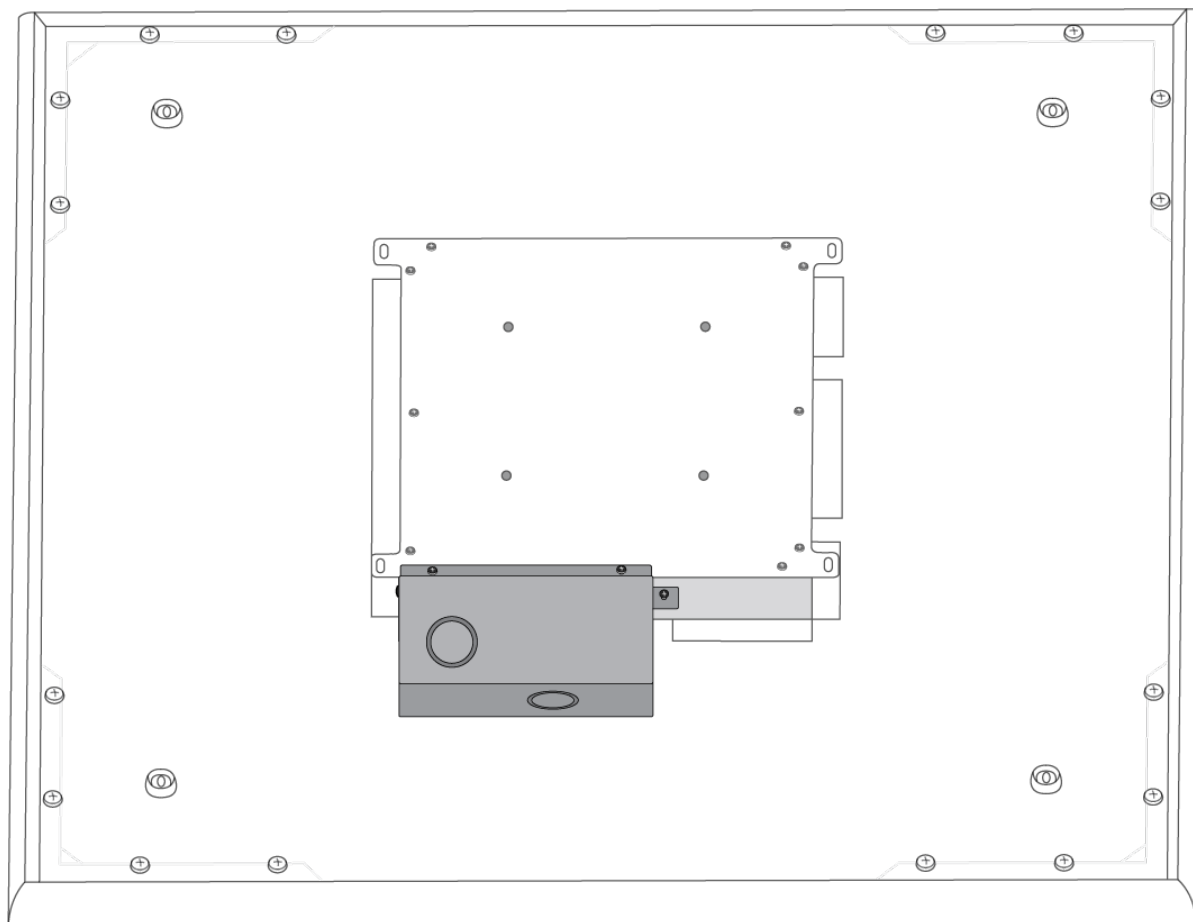

Software Installation, Management, and Security

Controlling Devices with Shure Designer Software

You can control this device using Shure Designer software. Designer enables integrators and system planners to design audio coverage for installations using MXA microphones and other Shure networked components.

With Designer, you can:

- Design audio coverage, whether online or offline
- Control Shure device settings and coverage
- Route audio between Shure devices
- Push settings to many devices at once
- Create and reuse templates across multiple locations and projects
- Import floor plans

To access your device in Designer:

1. Download and install Designer on a computer connected to the same network as your device.
2. Open Designer, and check that you're connected to the correct network in Settings.
3. Click Online devices. A list of online devices appears.

4. To identify devices, click the product icon to flash the lights on a device. Select your device in the list and click Configure to open the device's configuration window.

Learn more and download at www.shure.com/designer.

Accessing the Web Application

The Shure Web Server Discovery application finds all Shure devices on the network that feature a web-based GUI. Follow these steps to install the software and access the web application:

① Install the Shure Discovery application

Download and install the Shure Discovery application from www.shure.com. This automatically installs the required Bonjour device discovery tool on the computer.

② Connect the network

Ensure the computer and the hardware are on the same network.

③ Launch the Discovery application

The app displays all Shure devices that feature a GUI.

④ Identify the hardware

Double-click on a device to open its GUI in a web browser.

⑤ Bookmark the device's web application (recommended)

Bookmark the device's DNS name to access the GUI without the Shure Discovery app.

Web Application Browser Compatibility

The web application is compatible with all HTML5-supported browsers. To ensure the best performance, disabling hardware acceleration and unused plug-ins is recommended.

Accessing the Web Application without the Discovery App

If the Discovery application is not installed, the web application can be accessed by typing the DNS name into an internet browser. The DNS name is derived from model of the unit, in combination with the last three bytes (six digits) of the MAC address, and ending in .local.

Format Example: If the MAC address of a unit is 00:0E:DD:AA:BB:CC, then the link is written as follows:

MXA910: <http://MXA910-aabbcc.local>

Firmware Updates

Firmware is embedded software in each component that controls functionality. Periodically, new versions of firmware are developed to incorporate additional features and enhancements. To take advantage of design improvements, new versions of the firmware can be uploaded and installed using the Shure Update Utility. Software is available for download from <http://www.shure.com>.

Important: When components are connected through the Shure MXW Audio Network Interface, their firmware must be updated on one device at a time prior to updating the MXW Audio Network Interface firmware. Attempting to update all devices at once will cause the interface to reboot after its firmware is updated, and the connection to other networked components will be lost.

Perform the following steps to update the firmware:

CAUTION! Ensure the device has a stable network connection during the update. Do not turn off the device until the update is complete.

1. Connect the device and computer to the same network (set to the same subnet).
2. Download Shure Update Utility app and install it.
3. Open the application.
4. Click Check For Updates... button to view new firmware versions available for download.
5. Select the desired firmware and press Download to download it to the Firmware Library.
6. From the Update Devices tab, select the new firmware and press Send Updates... to begin the firmware update, which overwrites the existing firmware on the device.

Note: After updating, you may need to clear your browser's cache to display updates to the device's web application.

Firmware Release Requirements

All devices comprise a network with multiple communications protocols that work together to ensure proper operation. The recommended best practice is that all devices are on an identical release. To view the firmware version of each device on the network, open the component user interface, and look under Settings > About.

The format for Shure device's firmware is MAJOR.MINOR.PATCH. (Ex. 1.6.2 where 1 is the Major firmware level, 6 is the Minor firmware level, and 2 is the Patch firmware level.) At minimum, devices that operate on the same subnet should have identical MAJOR and MINOR release numbers.

- Devices of different MAJOR releases are not compatible.
- Differences in the PATCH firmware release level may introduce undesired inconsistencies.

Microphone Configuration

Software Overview

Designer allows administrators and technicians to control:

Coverage: Adjust lobe width and location, select templates, save or load presets, customize light bar settings, and run automatic setup.

Channels: Adjust and monitor channel levels, mute channels or channel groups, configure automix settings, and adjust equalizer settings.

Settings: Control network IP settings, device name, passwords, languages, firmware identification, and device reset.

Software Workflow Basics

Think of each lobe as an individual microphone. If there were 8 microphones on the table, each one could be physically moved according to seating arrangements, and would be plugged into a mixer with independent gain and channel controls. With the Microflex Advance Ceiling Array Microphone, Designer delivers control over the physical coverage and audio channel settings, with user presets to quickly switch between configurations. Each lobe is moved according to seating arrangements, with three width settings to change the size of the coverage area. Independent mixer channels control the level and audio properties for each lobe.

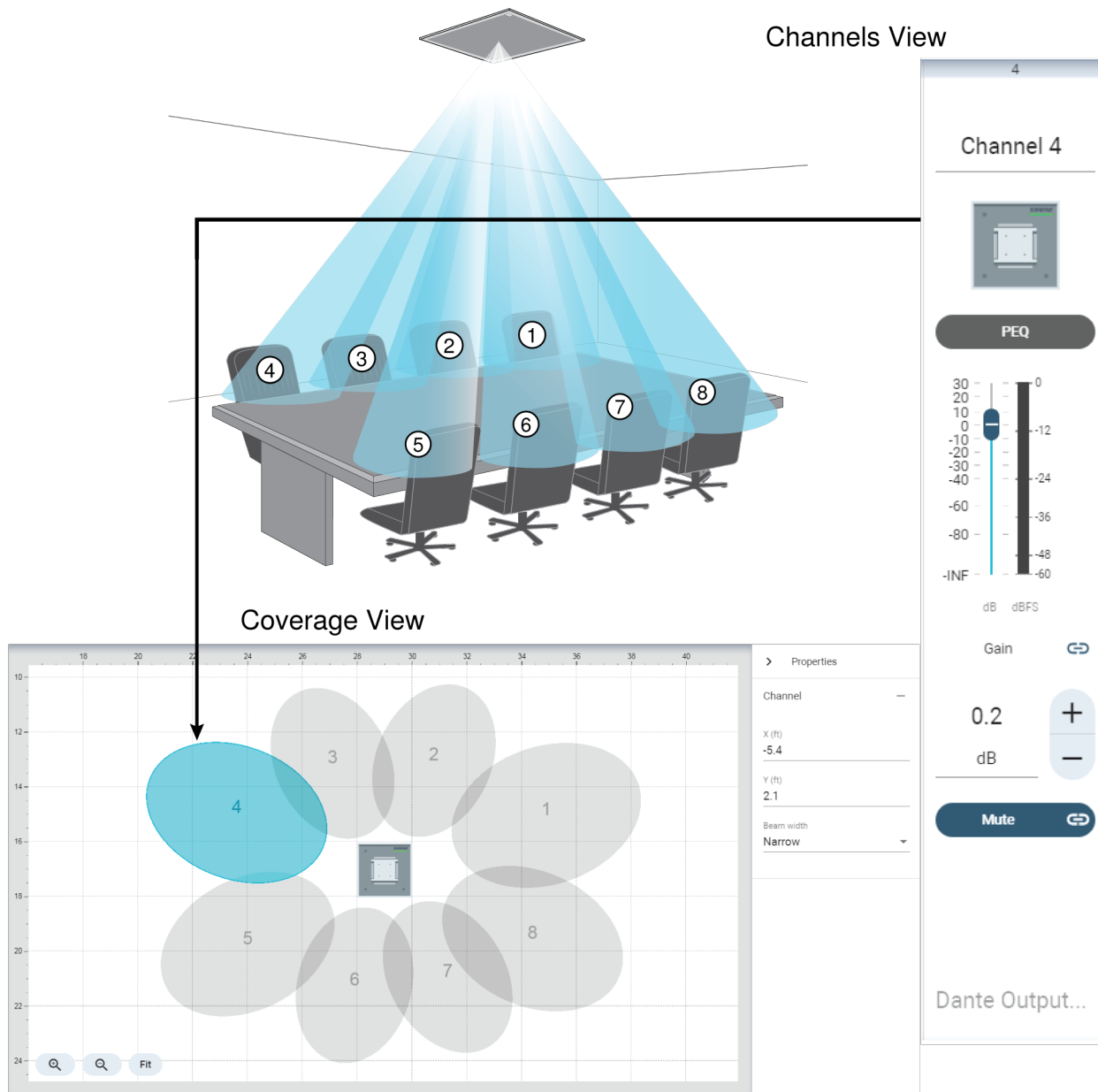

Each lobe is represented graphically and can be dragged into place. A corresponding mixer channel provides control over audio settings for each lobe.

Configuring Microphone Coverage for MXA910

To configure the MXA910, follow these steps:

Set Device Properties

Select the device and set the properties:

1. Enter a value for the device height (the distance between the floor and the microphone). By default, the device height matches the ceiling height, though you can adjust them independently.
2. Move and rotate the device to match your layout.

Position Microphone Coverage

1. Add channels by clicking Add channel above the workspace.
2. Enter the talker height by selecting a channel and providing the value in the Properties. This ensures accurate aiming.
3. Move channels to cover the appropriate areas:
 - Channels are independently selectable and can be moved anywhere within the maximum allowed coverage area. If dragged outside of this region, lobes turn red and revert back to the last acceptable position.
 - Position the channels by dragging or nudging them into place. Distance values to the device and to the workspace 0,0 are calculated in the properties panel.
 - Use the grid to measure the precise placement.
4. As you move channels into position, have someone talk from each position and listen to the channel. Move lobes accordingly to get the best position for each one.

You'll see the lobes moving in Designer's coverage map as participants shift positions, which is the Autofocus technology in action. Autofocus fine-tunes each lobe's position in real time, even if meeting participants lean back or stand up.

Adjust Channel Width

Independent width control makes it possible for some channels to capture individual talkers (narrow), while others cover multiple talkers (wide).

To change a channel width:

1. Select the channel
2. Choose a width setting from the pull-down menu. The width is calculated and displayed, based on the lobe location and heights entered for the device and talker.

Width Settings:

- Narrow (35°)
- Medium (45°)
- Wide (55°)

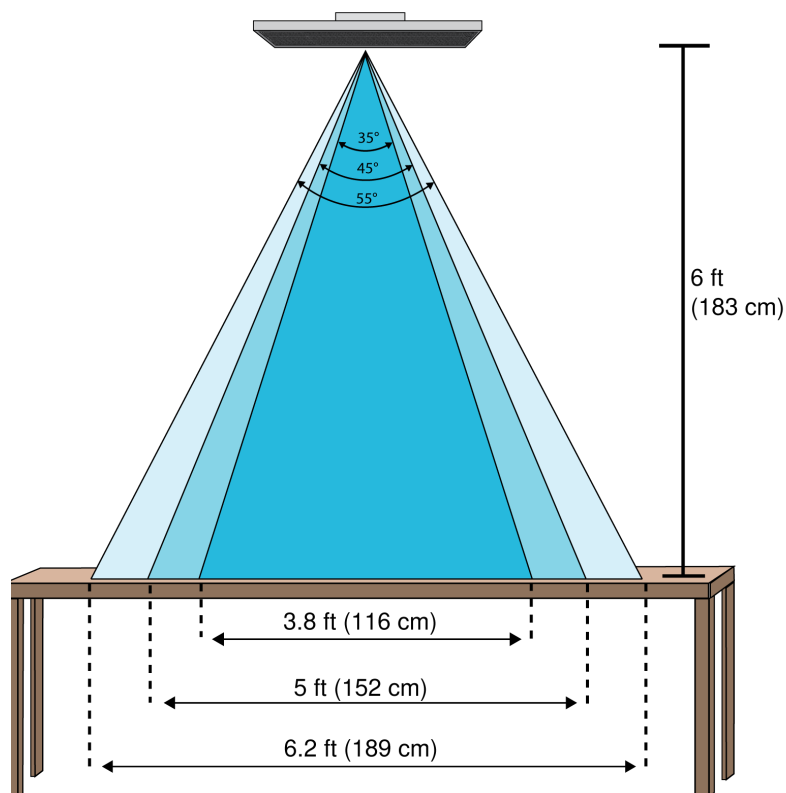

Channel widths for the three settings with the microphone 6 feet above a table

Use Auto Position

You can use Auto position to correctly position the lobe for a selected channel:

1. Select a channel.
2. Click Auto position.
3. Ensure that you have the correct channel selected and the talker height specified.
4. Have someone talk in each area that you want to cover in the room and click Listen. Designer listens and determines the correct position and width for the channel.
5. A confirmation dialog displays when Designer determines the correct position and width. You may want to listen to each lobe position yourself to check that they're positioned correctly.

Using Autofocus to Improve Coverage

This microphone uses built-in Autofocus technology to fine-tune each lobe's position in real time, even if meeting participants lean back or stand up. You'll see the lobes moving in Designer's coverage map as participants shift positions. Autofocus only responds to in-room sound sources.

For best results with Autofocus, always route a reference source to the microphone's AEC Reference In channel. Even if you're only using direct outputs from the microphone and a different DSP, route a reference signal to the microphone's AEC Reference In channel to take full advantage of Autofocus.

Adjusting Levels

Gain levels on MicroflexAdvance microphones must be set for each saved coverage preset to ensure an optimized gain structure for all seating scenarios. Always adjust the levels before making any changes to automix settings to ensure the best performance.

1. Perform a level check for each coverage area, using a typical speech volume. Adjust the faders so the meters are peaking at approximately -20 dBFS.
2. Adjust the equalizer settings to optimize speech intelligibility and minimize noise (such as low-frequency rumble caused by HVAC systems).
3. If equalizer settings cause a significant increase or decrease in levels, make any necessary level adjustments according to step 1.

When to Use the Channel and IntelliMix Gain Faders

There are 2 different gain faders that serve different purposes:

Channel Gain (Pre-Gate)

To adjust, go to Channels. These faders affect a channel's gain before it reaches the automixer and therefore affect the automixer's gating decision. Boosting the gain here will make the lobe more sensitive to sound sources and more likely to gate on. Lowering gain here makes the lobe less sensitive and less likely to gate on. If you're only using direct outputs for each channel without the automixer, you only need to use these faders.

IntelliMix Gain (Post-Gate)

To adjust, go to Configuration > IntelliMix. These faders adjust a channel's gain after the lobe has gated on. Adjusting the gain here will not affect the automixer's gating decision. Only use these faders to adjust the gain of a talker after you are satisfied with the automixer's gating behavior.

Parametric Equalizer (PEQ)

Maximize audio quality by adjusting the frequency response with the parametric equalizer.

Common equalizer applications:

- Improve speech intelligibility
- Reduce noise from HVAC systems or video projectors
- Reduce room irregularities
- Adjust frequency response for reinforcement systems

To turn off all EQ filters, select Bypass all EQ.



If you're using Shure Designer software to configure your system, please check the Designer help section for more about this topic.

Setting Filter Parameters

Adjust filter settings by manipulating the icons in the frequency response graph, or by entering numeric values. Disable a filter using the check-box next to the filter.

Filter Type

Only the first and last band have selectable filter types.

Parametric: Attenuates or boosts the signal within a customizable frequency range

Low Cut: Rolls off the audio signal below the selected frequency

Low Shelf: Attenuates or boosts the audio signal below the selected frequency

High Cut: Rolls off the audio signal above the selected frequency

High Shelf: Attenuates or boosts the audio signal above the selected frequency

Frequency

Select the center frequency of the filter to cut/boost

Gain

Adjusts the level for a specific filter (+/- 30 dB)

Q

Adjusts the range of frequencies affected by the filter. As this value increases, the bandwidth becomes thinner.

Width

Adjusts the range of frequencies affected by the filter. The value is represented in octaves.

Note: The Q and width parameters affect the equalization curve in the same way. The only difference is the way the values are represented.

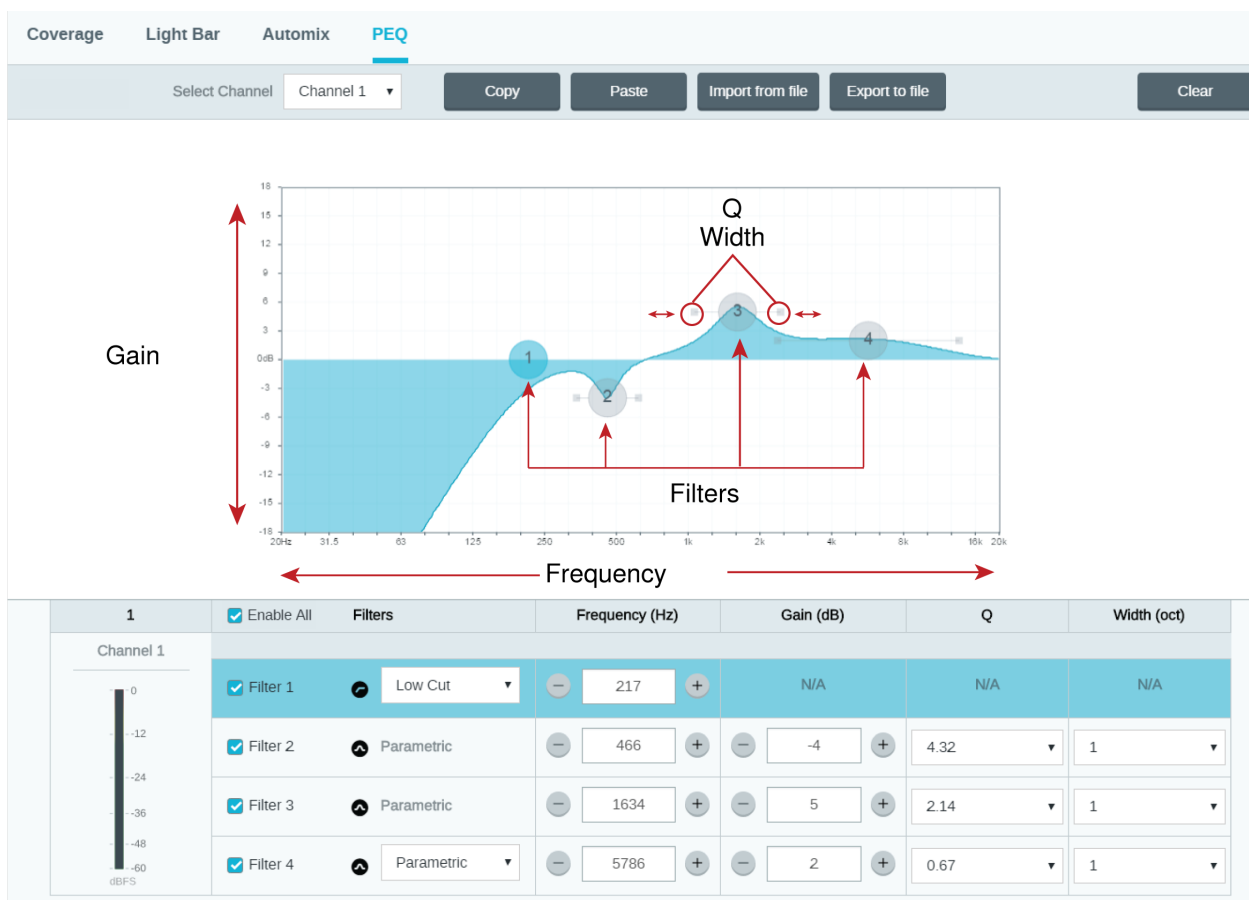

Copy, Paste, Import, and Export Equalizer Channel Settings

These features make it simple to use effective equalizer settings from a previous installation, or simply accelerate configuration time.

Copy and Paste

Use to quickly apply the same PEQ setting across multiple channels.

1. Select the channel from the pull-down menu in the PEQ screen.
2. Select Copy
3. In the pull-down menu, select the channel to apply the PEQ setting and select Paste.

Import and Export

Use to save and load PEQ settings from a file on a computer. This is useful for creating a library of reusable configuration files on computers used for system installation.

Export

Choose a channel to save the PEQ setting, and select Export to file.

Import

Choose a channel to load the PEQ setting, and select Import from file.

When to Use the Channel and Automix Equalizers

Apply **Automix EQ** to make system-wide changes, such as a treble boost to improve speech clarity. Use **Channel EQ** to make adjustments to a specific channel. For example, to reduce unwanted noise picked up by only one channel.

Equalizer Applications

Conferencing room acoustics vary based on room size, shape, and construction materials. Use the guidelines in following table.

EQ Application	Suggested Settings
Treble boost for improved speech intelligibility	Add a high shelf filter to boost frequencies greater than 1 kHz by 3-6 dB
HVAC noise reduction	Add a low cut filter to attenuate frequencies below 200 Hz
Reduce flutter echoes and sibilance	Identify the specific frequency range that "excites" the room: <ol style="list-style-type: none"> 1. Set a narrow Q value. 2. Increase the gain to between +10 and +15 dB, and then experiment with frequencies between 1 kHz and 6 kHz to pinpoint the range of flutter echoes or sibilance. 3. Reduce the gain at the identified frequency (start between -3 and -6 dB) to minimize the unwanted room sound.
Reduce hollow, resonant room sound	Identify the specific frequency range that "excites" the room: <ol style="list-style-type: none"> 1. Set a narrow Q value. 2. Increase the gain to between +10 and +15 dB, and then experiment with frequencies between 300 Hz and 900 Hz to pinpoint the resonant frequency.

EQ Application	Suggested Settings
	3. Reduce the gain at the identified frequency (start between -3 and -6 dB) to minimize the unwanted room sound.

EQ Contours

Use the built-in equalizer contours to quickly apply EQ changes to all channels. EQ contours are separate from the per-channel EQ settings. Applying both EQ contours and per-channel EQ has a cumulative effect, meaning that the EQ changes stack on top of each other.

To enable a contour, open the web application and select a contour in the device options section.

Off: Turns off any active EQ contours

High Pass (default): 300 Hz low-cut filter

Low Shelf: 960 Hz, -10 dB low-shelf filter

Multi-Band: 200 Hz low-cut filter, parametric 450 Hz, -10 dB, 2.87 Q, ½ octave parametric, 900 Hz, -10 dB, 2.87 Q, ½ octave parametric

Click Bypass all EQ to quickly bypass any EQ contours or channel EQ settings.

Best Practices

- Listen to and test your system as you make EQ changes, and make sure they work for your specific room.
- When using with a P300 audio conferencing processor, turn off the microphone's channel EQ and EQ contours. Use the P300 to make EQ adjustments.

Custom Presets

Use presets to quickly save and recall settings. Up to 10 presets can be stored on each device to match various seating arrangements. A preset saves all device settings except for the Device Name, IP Settings, and Passwords. Importing and exporting presets into new installations saves time and improves workflow. When a preset is selected, the name displays above the preset menu. If changes are made, an asterisk appears next to the name.

Note: Use the default settings preset to revert to the factory configuration (excludes Device Name, IP Settings, and Passwords).

Open the presets menu to reveal preset options:

save as preset:	Saves settings to the device
load preset:	Opens a configuration from the device
import from file:	Downloads a preset file from a computer onto the device. Files may be selected through the browser or dragged into the import window.
export to file:	Saves a preset file from the device onto a computer

Mute and Fader Groups

Add channels to a Mute group or Fader group to link the corresponding controls together. For example, if channels 1, 2, and 3 are added to a Mute group, muting any of those individual channels will mute all of the grouped channels.



If you're using Shure Designer software to configure your system, please check the Designer help section for more about this topic.

Encryption

Audio is encrypted with the Advanced Encryption Standard (AES-256), as specified by the US Government National Institute of Standards and Technology (NIST) publication FIPS-197. Shure devices that support encryption require a passphrase to make a connection. Encryption is not supported with third-party devices.

To activate encryption:

1. Open the Settings menu and select the General tab.
2. Select Enable Encryption.
3. Enter a passphrase. All devices must use the same passphrase to establish an encrypted connection.

Important: For encryption to work:

- All Shure devices on your network must use encryption.
- Disable AES67 in Dante Controller. AES67 and AES-256 cannot be used at the same time.



If you're using Shure Designer software to configure your system, please check the Designer help section for more about this topic.

Automix

Automix Channel

This channel automatically mixes the audio from all selected channels to deliver a convenient, single output. To adjust the automix channel settings, select the IntelliMix tab. All IntelliMix DSP blocks can be applied to the automix channel.

To use the automix channel, do the following:

1. Send to Mix is automatically selected (blue) for all channels. To exclude channels from the automix channel and treat them as individual direct outputs, deselect Send to Mix (gray).
2. Route the automix channel in Dante Controller to the desired output.

Automix Modes

Gating

Gating mode delivers fast-acting, seamless channel gating and consistent perceived ambient sound levels. Off-attenuation in this mode is fixed at -20 dB per channel, regardless of the number of open channels.

Gain Sharing

Gain sharing mode dynamically balances system gain between open and closed channels. The system gain remains consistent by distributing gain across channels to equal one open channel. The scaled gain structure helps to reduce noise when there is a high channel count. When fewer channels are used, the lower off-attenuation provides transparent gating.

Manual

Manual mode sums all active tracks and sends the summed signal over a single Dante output. This provides the option to route an individual signal for reinforcement or recording, without enabling automixing. The settings from the faders in the standard monitoring view apply to the summed output.

Automix Settings

Leave Last Mic On

Keeps the most recently used microphone channel active. The purpose of this feature is to keep natural room sound in the signal so that meeting participants on the far end know the audio signal has not been interrupted.

Gating Sensitivity

Changes the threshold of the level at which the gate is opened

Off Attenuation

Sets the level of signal reduction when a channel is not active

Hold Time

Sets the duration for which the channel remains open after the level drops below the gate threshold

Maximum Open Channels

Sets the maximum number of simultaneously active channels

Priority

When selected, this channel gate activates regardless of the number of maximum open channels.

Always On

When selected, this channel will always be active.

Send to Mix

When selected, sends the channel to the automix channel.

Solo

Mutes all of the other channels

Automix Gain Meter

When enabled, changes gain meters to display automix gating in real time. Channels that gate open will display more gain than channels that are closed (attenuated) in the mix.

Automix Modes (Firmware <4.x only)

Classic

Classic mode emulates the Shure SCM820 automixer (in its default settings). It is renowned for fast-acting, seamless channel gating and consistent perceived ambient sound levels. Off-attenuation in this mode is fixed at -20 dB per channel, regardless of the number of open channels.

Smooth

In Smooth mode, Off-attenuation settings for each channel are scaled, depending on the number of open channels. The scaled gain structure helps to reduce noise when there is a high channel count. When fewer channels are used, the lower off-attenuation provides transparent gating.

Number of channels enabled	Off-attenuation (dB)
2	-5
3	-8
4	-10
5	-12
6	-13
7	-14
8	-15

Custom

Custom mode provides control over all automixing parameters. This mode is useful when adjustments must be made to one of the preset modes to fit a particular application. If parameters are changed in smooth or classic mode, custom mode automatically activates.

Manual

Manual mode sums all active tracks and sends the summed signal over a single Dante output. This provides the option to route the signal for reinforcement or recording, without enabling automixing. The settings from the faders in the standard monitoring view apply to the summed output.

IntelliMix DSP

This device contains IntelliMix digital signal processing blocks that can be applied to the automix channel output. The DSP blocks include:

- Acoustic echo cancellation (AEC)
- Automatic gain control (AGC)
- Noise reduction
- Compressor
- Delay

To access the DSP blocks, select the IntelliMix tab. When enabled, each DSP block will be colored.

Selecting Bypass IntelliMix will bypass the following DSP blocks: AEC, AGC, noise reduction, compressor, and delay.

DSP Best Practices

- Apply DSP blocks only as needed. Run a test of your system without DSP, and then add processing as needed to fix any issues that you hear in the audio signal.
- Unless you encounter video that lags behind audio, set Delay to off.
- DSP blocks do not affect whether the automixer gates a channel on or off.

Using Designer's Optimize Workflow

Designer's Optimize workflow speeds up the process of connecting systems with at least 1 microphone and 1 audio processor. Optimize also creates mute control routes in locations with MXA network mute buttons. When you select Optimize in a location, Designer does the following:

- Creates audio routes and mute control routes
- Adjusts audio settings
- Turns on mute synchronization
- Enables LED logic control for applicable devices

The settings are optimized for your particular combination of devices. You can customize settings further, but the Optimize workflow gives you a good starting point.

After optimizing a location, you should check and adjust settings to fit your needs. These steps may include:

- Deleting unnecessary routes.
- Checking levels and adjusting gain.
- Verifying that AEC reference signals are correctly routed.
- Fine-tuning DSP blocks as needed.

Compatible devices:

- MXA910
- MXA710
- MXA310
- P300
- IntelliMix Room
- ANIUSB-MATRIX
- MXN5-C
- MXA Network Mute Button

To use the Optimize workflow:

1. Place all relevant devices in a location.
2. Select Optimize. Designer optimizes microphone and DSP settings for your equipment combination.

If you remove or add devices, select Optimize again.

Acoustic Echo Cancellation

In audio conferencing, a far-end talker may hear their voice echo as a result of a near-end microphone capturing audio from loudspeakers. Acoustic echo cancellation (AEC) is a DSP algorithm which identifies the far-end signal and stops it from being captured by the microphone to deliver clear, uninterrupted speech. During a conference call, the AEC works constantly to optimize processing as long as far-end audio is present.

When possible, optimize the acoustic environment using the following tips:

- Reduce speaker volume
- Position speakers farther from microphones
- Avoid pointing speakers directly at microphone coverage areas

Selecting a Reference Signal for AEC

To apply AEC, provide a far end reference signal. For best results, use the signal that also feeds your local reinforcement system.

P300: Go to Schematic and click any AEC block. Choose the reference source, and the reference source changes for all AEC blocks.

MXA910: Route a far-end signal to the AEC Reference In channel.

IntelliMix Room: Go to Schematic and click an AEC block. Choose the reference source. Each block can use a different reference source, so set the reference for each AEC block.

Designer's Optimize workflow automatically routes an AEC reference source, but it's a good idea to check that Designer chooses the reference source you want to use.

AEC Settings

Reference Meter

Use the reference meter to visually verify the reference signal is present. The reference signal should not be clipping.

ERLE

Echo return loss enhancement (ERLE) displays the dB level of signal reduction (the amount of echo being removed). If the reference source is connected properly, the ERLE meter activity generally corresponds to the reference meter.

Reference

Indicates which channel is serving as the far end reference signal.

Non-Linear Processing

The primary component of the acoustic echo canceller is an adaptive filter. Non-linear processing supplements the adaptive filter to remove any residual echo caused by acoustic irregularities or changes in the environment. Use the lowest possible setting that is effective in your room.

Low: Use in rooms with controlled acoustics and minimal echoes. This setting provides the most natural sound for full duplex.

Medium: Use in typical rooms as a starting point. If you hear echo artifacts, try using the high setting.

High: Use to provide the strongest echo reduction in rooms with bad acoustics, or in situations where the echo path frequently changes.

Noise Reduction

Noise reduction significantly reduces the amount of noise in the signal caused by projectors, HVAC systems, or other environmental noise. It is a dynamic processor, which calculates the noise floor in the room and removes noise throughout the entire spectrum with maximum transparency.

Settings

The noise reduction setting (low, medium, or high) represents the amount of reduction in dB. Use the lowest possible setting that effectively lowers noise in the room.

Automatic Gain Control (AGC)

Automatic gain control automatically adjusts channel levels to ensure consistent volume for all talkers, in all scenarios. For quieter voices, it increases gain; for louder voices, it attenuates the signal.

Enable AGC on channels where the distance between the talker and the microphone may vary, or in rooms where many different people will use the conferencing system.

Automatic gain control happens post-gate (after the automixer), and will not affect when the automixer gates on or off.

Target Level (dBFS)

Use -37 dBFS as a starting point to ensure adequate headroom, and adjust if necessary. This represents the RMS (average) level, which is different from setting the input fader according to peak levels to avoid clipping.

Maximum Boost (dB)

Sets the maximum amount of gain that can be applied

Maximum Cut (dB)

Sets the maximum attenuation that can be applied

Tip: Use the boost/cut meter to monitor the amount of gain added or subtracted from the signal. If this meter is always reaching the maximum boost or cut level, consider adjusting the input fader so the signal is closer to the target level.

Delay

Use delay to synchronize audio and video. When a video system introduces latency (where you hear someone speak, and their mouth moves later), add delay to align audio and video.

Delay is measured in milliseconds. If there is a significant difference between audio and video, start by using larger intervals of delay time (500-1000 ms). When the audio and video are slightly out of sync, use smaller intervals to fine-tune.

Compressor

Use the compressor to control the dynamic range of the selected signal.

Threshold

When the audio signal exceeds the threshold value, the level is attenuated to prevent unwanted spikes in the output signal. The amount of attenuation is determined by the ratio value. Perform a soundcheck and set the threshold 3-6 dB above average talker levels, so the compressor only attenuates unexpected loud sounds.

Ratio

The ratio controls how much the signal is attenuated when it exceeds the threshold value. Higher ratios provide stronger attenuation. A lower ratio of 2:1 means that for every 2 dB the signal exceeds the threshold, the output signal will only exceed the threshold by 1 dB. A higher ratio of 10:1 means a loud sound that exceeds the threshold by 10 dB will only exceed the threshold by 1 dB, effectively reducing the signal by 9 dB.

AES67

AES67 is a networked audio standard that enables communication between hardware components which use different IP audio technologies. This Shure device supports AES67 for increased compatibility within networked systems for live sound, integrated installations, and broadcast applications.

The following information is critical when transmitting or receiving AES67 signals:

- Update Dante Controller software to the newest available version to ensure the AES67 configuration tab appears.
- Before turning encryption on or off, you must disable AES67 in Dante Controller.
- AES67 cannot operate when the transmit and receive devices both support Dante.

Shure Device Supports:	Device 2 Supports:	AES67 Compatibility
Dante and AES67	Dante and AES67	No. Must use Dante.

Shure Device Supports:	Device 2 Supports:	AES67 Compatibility
Dante and AES67	AES67 without Dante. Any other audio networking protocol is acceptable.	Yes

Separate Dante and AES67 flows can operate simultaneously. The total number of flows is determined by the maximum flow limit of the device.

Sending Audio from a Shure Device

All AES67 configuration is managed in Dante Controller software. For more information, refer to the Dante Controller user guide.

1. Open the Shure transmitting device in Dante Controller.
2. Enable AES67.
3. Reboot the Shure device.
4. Create AES67 flows according to the instructions in the [Dante Controller user guide](#).

Receiving Audio from a Device Using a Different Audio Network Protocol

Third-party devices: When the hardware supports SAP, flows are identified in the routing software that the device uses. Otherwise, to receive an AES67 flow, the AES67 session ID and IP address are required.

Shure devices: The transmitting device must support SAP. In Dante Controller, a transmit device (appears as an IP address) can be routed like any other Dante device.

Networking and Dante

Digital Audio Networking

Dante™ digital audio is carried over standard Ethernet and operates using standard Internet Protocols. Dante provides low latency, tight clock synchronization, and high Quality-of-Service (QoS) to provide reliable audio transport to a variety of Dante devices. Dante audio can coexist safely on the same network as IT and control data, or can be configured to use a dedicated network.

Switch Recommendations for Dante Networking

In addition to the basic networking requirements, Dante audio networks should use a Gigabit network switch or router with the following features:

- Gigabit ports
- Quality of Service (QoS) with 4 queues
- Diffserv (DSCP) QoS, with strict priority
- Recommended: A managed switch to provide detailed information about the operation of each network link (port speed, error counters, bandwidth used)

Compatibility with Dante Domain Manager

This device is compatible with Dante Domain Manager software (DDM). DDM is network management software with user authentication, role-based security, and auditing features for Dante networks and Dante-enabled products.

Considerations for Shure devices controlled by DDM:

- When you add Shure devices to a Dante domain, set the local controller access to Read Write. Otherwise, you won't be able to access to Dante settings, perform a factory reset, or update device firmware.
- If the device and DDM can't communicate over the network for any reason, you won't be able to control Dante settings, perform a factory reset, or update device firmware. When the connection is reestablished, the device follows the policy set for it in the Dante domain.
- If Dante device lock is on, DDM is offline, or the configuration of the device is set to Prevent, some device settings are disabled. These include: Dante encryption, MXW association, AD4 Dante browse and Dante cue, and SCM820 linking.

See [Dante Domain Manager's documentation](#) for more information.

Dante Flows for Shure Devices

Dante flows get created any time you route audio from one Dante device to another. One Dante flow can contain up to 4 audio channels. For example: sending all 5 available channels from an MXA310 to another device uses 2 Dante flows, because 1 flow can contain up to 4 channels.

Every Dante device has a specific number of transmit flows and receive flows. The number of flows is determined by the type of Dante chip used in the device.

Unicast and multicast transmission settings also affect the number of Dante flows a device can send or receive. Using multi-cast transmission can help overcome unicast flow limitations.

Shure devices currently use 2 types of Dante chips:

Dante Platform	Shure Devices Using Platform	Unicast Transmit Flow Limit	Unicast Receive Flow Limit
Brooklyn II	ULX-D, SCM820, MXWAPT, MXWANI, MXA910, MXA710, P300	32	32
Ultimo/UltimoX	MXA310, ANI4IN, ANI4OUT, ANIUSB-MATRIX, ANI22, MXN5-C	2	2

[Learn more about Dante flows in our FAQs](#) or from [Audinate](#).

Cable Requirements

Always use Cat5E cable or higher.

QoS (Quality of Service) Settings

QoS settings assign priorities to specific data packets on the network, ensuring reliable audio delivery on larger networks with heavy traffic. This feature is available on most managed network switches. Although not required, assigning QoS settings is recommended.

Note: Coordinate changes with the network administrator to avoid disrupting service.

To assign QoS values, open the switch interface and use the following table to assign Dante-associated queue values.

- Assign the highest possible value (shown as 4 in this example) for time-critical PTP events
- Use descending priority values for each remaining packet.

Dante QoS Priority Values

Priority	Usage	DSCP Label	Hex	Decimal	Binary
High (4)	Time-critical PTP events	CS7	0x38	56	111000
Medium (3)	Audio, PTP	EF	0x2E	46	101110
Low (2)	(reserved)	CS1	0x08	8	001000
None (1)	Other traffic	BestEffort	0x00	0	000000

Note: Switch management may vary by manufacturer and switch type. Consult the manufacturer's product guide for specific configuration details.

For more information on Dante requirements and networking, visit www.audinate.com.

Networking Terminology

PTP (Precision Time Protocol): Used to synchronize clocks on the network

DSCP (Differentiated Services Code Point): Standardized identification method for data used in layer 3 QoS prioritization

Networking Best Practices

Use the following best practices when setting up a network to ensure reliable communication:

- Always use a "star" network topology by connecting each component directly to the switch or router.
- Connect all Shure networked devices to the **same network** and set to the **same subnet**. It is also required in order to open the web application for a device.
- Devices on separate networks require an audio processor or conferencing software to carry audio between them. See the system planning and gear requirements section for network setup information and configuration examples.
- Use only 1 DHCP server per network. Disable DHCP addressing on additional servers.
- Power on the switch and DHCP server prior to MXA equipment.
- To expand the network, use multiple Ethernet switches in a star topology.
- All devices must be at the same firmware revision level.

Network Audio and Shure Control Data

MicroflexAdvance devices transport two types of data over the network: Shure Control and Network Audio.

Shure Control

The Shure Control carries data for the control software operation, firmware updates and 3rd party control systems (AMX, Crestron).

Network Audio

This network carries both the Dante digital audio and the control data for Dante Controller. The network audio requires a wired, gigabit Ethernet connection to operate.

Device IP Settings

Configure IP

Sets IP mode of the selected network interface:

- **Auto (DHCP):** For automatic assignment of IP addresses.
- **Manual (Static):** For Static IP addresses.

IP Settings

View and edit the IP Address, Subnet Mask, and Gateway for each network interface.

MAC Address

The network interface's unique identification.

Configuring IP Settings

IP configurations are managed in Shure Designer software. By default, they are set to Automatic (DHCP) mode. DHCP mode enables the devices to accept IP settings from a DHCP server, or automatically fall back to Link-Local settings when no DHCP is available. IP addresses may also be manually set.

To configure the IP properties, follow these steps:

1. Open device's configuration window.
2. Go to the Settings tab and select Network.
3. Select Auto or Manual. If Auto is used, addresses will be automatically assigned. For Manual setup, follow the instructions on manual configuration.

Manually Assigning Static IP Address

To manually assign IP addresses, follow these steps:

1. Open the device's configuration window in Designer.
2. Go to the Settings tab and select Network.
3. Select Manual as the Configure IP setting.
4. Enter the IP settings.

Setting Latency

Latency is the amount of time for a signal to travel across the system to the outputs of a device. To account for variances in latency time between devices and channels, Dante has a predetermined selection of latency settings. When the same setting is selected, it ensures that all Dante devices on the network are in sync.

These latency values should be used as a starting point. To determine the exact latency to use for your setup, deploy the setup, send Dante audio between your devices, and measure the actual latency in your system using Audinate's Dante Controller software. Then round up to the nearest latency setting available, and use that one.

Use Audinate's Dante Controller software to change latency settings.

Latency Recommendations

Latency Setting	Maximum Number of Switches
0.25 ms	3
0.5 ms (default)	5
1 ms	10
2 ms	10+

Operating the Control Software over Wi-Fi

When operating the web application over Wi-Fi, it's important to set up the wireless router properly for best performance. The system employs several standard-based protocols that rely on multicast. Wi-Fi treats broadcast and multicast packets different-

ly than general packets for backward compatibility reasons. In some cases, the Wi-Fi router will limit the multicast packet transmission rate to a value that is too slow for web application to properly operate.

Wi-Fi routers typically support 802.11b, 802.11a/g, and/or 802.11n standards. By default, many Wi-Fi routers are configured to allow older 802.11b devices to operate over the network. In this configuration, these routers will automatically limit the multicast data rates (or sometimes referred to as 'basic rate', or 'management rate') to 1-2Mbps.

Note: A Wi-Fi connection can only be used for the control software. Network audio cannot be transmitted over Wi-Fi.

Tip: For larger wireless microphone configurations, it's recommended to increase the multicast transmission rate to provide adequate bandwidth.

Important: For best performance, use a Wi-Fi router that does not limit the multicast rate to 1-2 Mbps.

Shure recommends the following Wi-Fi router brands:

- Cisco
- Linksys
- Apple

Packet Bridge

Packet bridge enables an external controller to obtain IP information from the control interface of a Shure device. To access the packet bridge, an external controller must send a query packet over **unicast UDP*** to **port 2203** on the Dante interface of the Shure device.

1. Send a UDP packet with a minimum 1-byte payload .

Note: The maximum accepted payload 140 bytes. Any content is allowed.

2. The Shure device will send a response packet over unicast UDP to the controller, using a destination UDP port identical to the source port of the query packet. The payload of the response packet follows this format:

Bytes	Content
0-3	IP address, as 32-bit unsigned integer in network order
4-7	Subnet mask, as 32-bit unsigned integer in network order
8-13	MAC address, as array of 6 bytes

Note: The Shure device should respond in less than one second on a typical network. If there is no response, try sending the query again after verifying the destination IP address and port number.

*UDP: User Datagram Protocol

IP Ports and Protocols

Shure Control

Port	TCP/UDP	Protocol	Description	Factory Default
21	tcp	FTP	Required for firmware updates (otherwise closed)	Closed
22	tcp	SSH	Secure Shell Interface	Closed
23	tcp	Telnet	Not supported	Closed
68	udp	DHCP	Dynamic Host Configuration Protocol	Open

Port	TCP/UDP	Protocol	Description	Factory Default
80*	tcp	HTTP	Required to launch embedded web server	Open
443	tcp	HTTPS	Not supported	Closed
161	tcp	SNMP	Not supported	Closed
162	tcp	SNMP	Not supported	Closed
2202	tcp	ASCII	Required for 3rd party control strings	Open
5353	udp	mDNS [†]	Required for device discovery	Open
5568	udp	SDT [†]	Required for inter-device communication	Open
8023	tcp	Telnet	Debug console interface	Closed
8180	tcp	HTML	Required for web application	Open
8427	udp	Multicast SLP [†]	Required for inter-device communication	Open
64000	tcp	Telnet	Required for Shure firmware update	Open

Dante Audio & Controller

Port	TCP/UDP	Protocol	Description
162	udp	SNMP	Used by Dante
[319-320]*	udp	PTP [†]	Dante clocking
2203	udp	Custom	Required for packet bridge
4321, 14336-14600	udp	Dante	Dante audio
[4440, 4444, 4455]*	udp	Dante	Dante audio routing
5353	udp	mDNS [†]	Used by Dante
[8700-8706, 8800]*	udp	Dante	Dante Control and Monitoring
8751	udp	Dante	Dante Controller
16000-65536	udp	Dante	Used by Dante

*These ports must be open on the PC or control system to access the device through a firewall.

[†]These protocols require multicast. Ensure multicast has been correctly configured for your network.

Echo Reduction (Firmware <4.x only)

In audio conferencing, a talker may hear their voice echo as a result of the microphone capturing far-end audio from loudspeakers.

The echo reduction feature prevents the far-end signal from activating the microphone. Ideal for installations in which per-channel DSP echo cancellation is not within a project budget, echo reduction is highly effective for connecting directly to a computer or video codec which hosts a single-channel echo canceller.

How It Works

An echo reference signal from the far end is routed through Dante Controller software to the microphone's processing algorithm. The processor uses this signal to prevent the microphone from gating on and capturing audio from the loudspeakers.

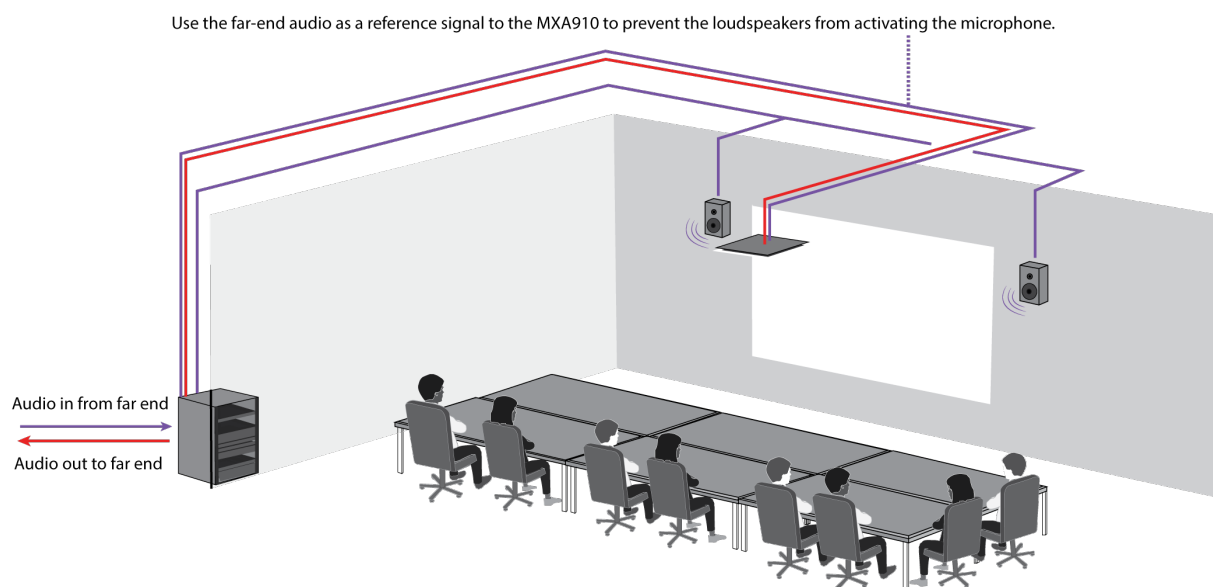

Enabling Echo Reduction

1. Use Dante Controller software to route the incoming far end audio signal to the Echo Reduction Reference In channel on the MXA910.
2. In the MXA910 web application, enter Configuration> AUTOMIX
3. Enable echo reduction by selecting a strength setting in the pull-down menu. Soft, medium, and hard settings provide far-end attenuation and apply gain to the reference channel to ensure proper gating. **Note:** the off-attenuation setting changes to -56 dB, and the Leave last microphone on setting is set to OFF when echo reduction is enabled.

Using a Third-Party Control System

This device receives logic commands over the network. Many parameters controlled through Designer can be controlled using a third-party control system, using the appropriate command string.

Common applications:

- Mute

- LED color and behavior
- Loading presets
- Adjusting levels

A complete list of command strings is available at:

pubs.shure.com/command-strings/MXA910.

Troubleshooting

Problem	Solution
Software lags in Google Chrome browser	Problem is browser-related. Turn off hardware acceleration option in Chrome.
Sound quality is muffled or hollow	Check that lobes have been aimed to the desired area. Use equalizer to adjust frequency response on a single channel or on the automix channel. See the equalizer applications for the appropriate use.
Microphone does not show up in device discovery	<p>Ensure the devices are powered</p> <p>Ensure PC and equipment are on the same network and set to the same subnet</p> <p>Turn off other network interfaces not used to connect to the device (including WiFi)</p> <p>Check that DHCP server is functioning (if applicable)</p> <p>Reset the device if necessary</p>
Audio is not present or is quiet/distorted	<p>Check cables</p> <p>Verify that channels are not muted</p> <p>Make sure channels are aimed in the right direction</p> <p>Check that fader levels are not set too low</p> <p>If using automixing, check the settings to ensure channels are gating on/off properly</p>
No lights	Check if brightness is disabled or if any Light Bar settings are turned off.
Auto-positioning identifies incorrect location	If talker is in a corner or very close to a wall, acoustic reflections may interfere with localization accuracy. Try automatic positioning again, and if the issue persists, manual positioning may be necessary.
Microphone does not power on	<p>The network switch must supply Power over Ethernet. Otherwise, a PoE injector must be used</p> <p>Check network cables and connections</p>

Important Product Information

The equipment is intended to be used in professional audio applications.

Note: This device is not intended to be connected directly to a public internet network.

EMC conformance to Environment E2: Commercial and Light Industrial. Testing is based on the use of supplied and recommended cable types. The use of other than shielded (screened) cable types may degrade EMC performance.

Changes or modifications not expressly approved by Shure Incorporated could void your authority to operate this equipment.

Industry Canada ICES-003 Compliance Label: CAN ICES-3 (B)/NMB-3(B)

Authorized under the verification provision of FCC Part 15B.

Please follow your regional recycling scheme for batteries, packaging, and electronic waste.

Information to the user

This device complies with part 15 of the FCC Rules. Operation is subject to the following two conditions:

1. This device may not cause harmful interference.
2. This device must accept any interference received, including interference that may cause undesired operation.

Note: This equipment has been tested and found to comply with the limits for a Class B digital device, pursuant to part 15 of the FCC Rules. These limits are designed to provide reasonable protection against harmful interference in a residential installation. This equipment generates uses and can radiate radio frequency energy and, if not installed and used in accordance with the instructions, may cause harmful interference to radio communications. However, there is no guarantee that interference will not occur in a particular installation. If this equipment does cause harmful interference to radio or television reception, which can be determined by turning the equipment off and on, the user is encouraged to try to correct the interference by one or more of the following measures:

- Reorient or relocate the receiving antenna.
- Increase the separation between the equipment and the receiver.
- Connect the equipment to an outlet on a circuit different from that to which the receiver is connected.
- Consult the dealer or an experienced radio/TV technician for help.

The CE Declaration of Conformity can be obtained from: www.shure.com/europe/compliance

Authorized European representative:

Shure Europe GmbH

Headquarters Europe, Middle East & Africa

Department: EMEA Approval

Jakob-Dieffenbacher-Str. 12

75031 Eppingen, Germany

Phone: +49-7262-92 49 0

Fax: +49-7262-92 49 11 4

Email: info@shure.de

This product meets the Essential Requirements of all relevant European directives and is eligible for CE marking.

The CE Declaration of Conformity can be obtained from Shure Incorporated or any of its European representatives. For contact information please visit www.shure.com

Specifications

General

All specifications measured from narrow lobe width. Values for all widths are within ± 3 dB of these specifications unless otherwise noted.

Lobe Width

Adjustable	Narrow	35 degrees
	Medium	45 degrees
	Wide	55 degrees

Connector Type

RJ45

Power Requirements

Power over Ethernet (PoE), Class 0

Power Consumption

9W, maximum

Weight

5.1 kg (11.3 lbs)

Product Dimensions

MXA910xx	603.8 x 603.8 x 54.69 mm (23.77 x 23.77 x 2.15 in.) H x W x D
MXA910xx-60CM	593.8 x 593.8 x 54.69 mm (23.38 x 23.38 x 2.15 in.) H x W x D
MXA910W-A	603.8 x 603.8 x 54.69 mm (23.77 x 23.77 x 2.15 in.) H x W x D
MXA910W-US	603.8 x 603.8 x 54.69 mm (23.77 x 23.77 x 2.15 in.) H x W x D

control application

HTML5 Browser-based or Shure Designer

Plenum Rating

Requires Fyrewrap[®] fire protective wrap system (Included)

UL2043 (Suitable for Air Handling Spaces)

Dust Protection

IEC 60529 IP5X Dust Protected

Operating Temperature Range

-6.7°C (20°F) to 40°C (104°F)

Storage Temperature Range

-29°C (-20°F) to 74°C (165°F)

Audio

Frequency Response

180 to 17,000 Hz

AES67 or Dante Digital Output

Channel Count	10 total channels (8 independent transmit channels, 1 Automatic mixing transmit channel, 1 AEC reference in channel)
Sampling Rate	48 kHz
Bit Depth	24

Sensitivity

at 1 kHz

0.75 dBFS/Pa

Maximum SPL

Relative to 0 dBFS overload

93.25 dB SPL

Signal-To-Noise Ratio

Ref. 94 dB SPL at 1 kHz

83 dB A-weighted

Latency (Not including Dante latency)

Direct outputs	7 ms
Automix output (Includes IntelliMix processing)	18 ms

Self Noise

11 dB SPL-A

Dynamic Range

82.25 dB

Built-in Digital Signal Processing

MXA910 firmware 4.x or newer	Automatic mixing, Acoustic Echo Cancellation (AEC), Noise Reduction, Automatic Gain Control, Compressor, Delay, Equalizer (4-band Parametric), Mute, Gain (140 dB range)
MXA910 firmware 3.x or older	Automatic mixing, Echo Reduction, Equalizer (4-band Parametric), Mute, Gain (140 dB range)

Intelligibility Scale

Equivalent acoustic performance, compared to a cardioid gooseneck microphone (environment dependent)

Cardioid distance multiplied by 1.6

Acoustic Echo Cancellation Tail Length

Up to 250 ms

Networking

Cable Requirements

Cat 5e or higher (shielded cable recommended)

Polar Response

Polar response measured directly on-axis from a distance of 6 feet (1.83 m).

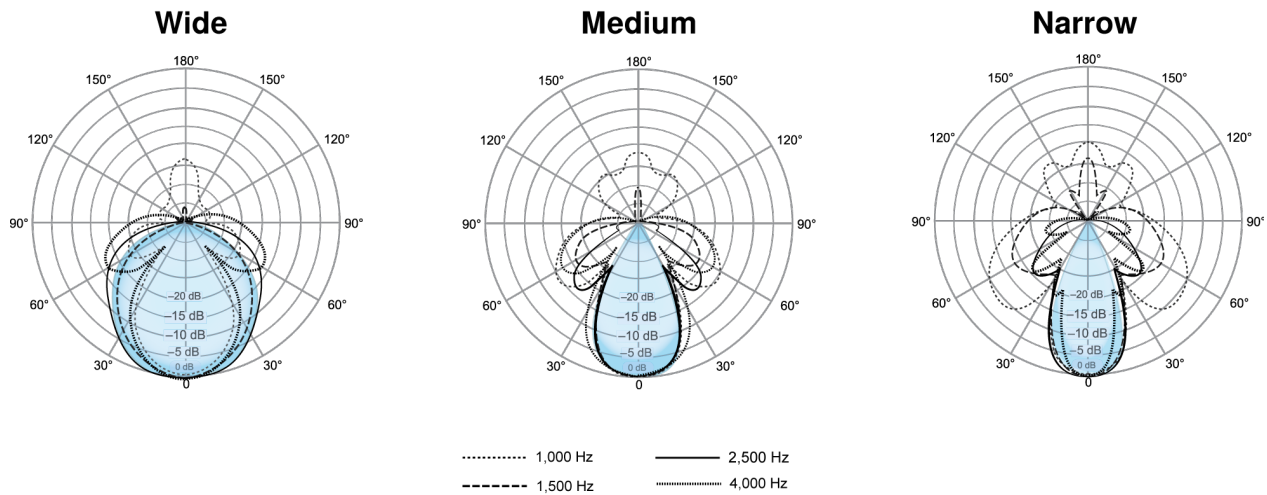

Frequency Response

Frequency response measured directly on-axis from a distance of 6 feet (1.83 m).

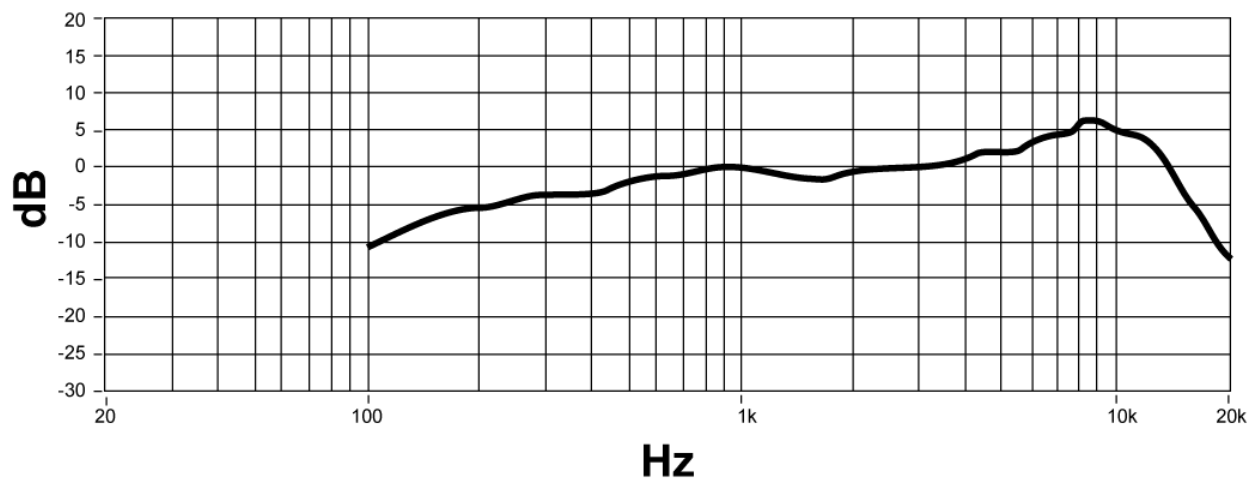

Lobe Sensitivity

The edge of the blue coverage area for each channel in the web application represents where the sensitivity reaches -6 dB. Understanding how lobe sensitivity is displayed helps to:

- Provide complete coverage in a space, either by adding lobes or changing the lobe width. This ensures the sensitivity is within 6 dB in all areas. It is acceptable for lobes to slightly overlap.

- Ensure that spacing and isolation are adequate to reduce noise and maximize automatic mixing performance.

Measured at 1 kHz, on-axis

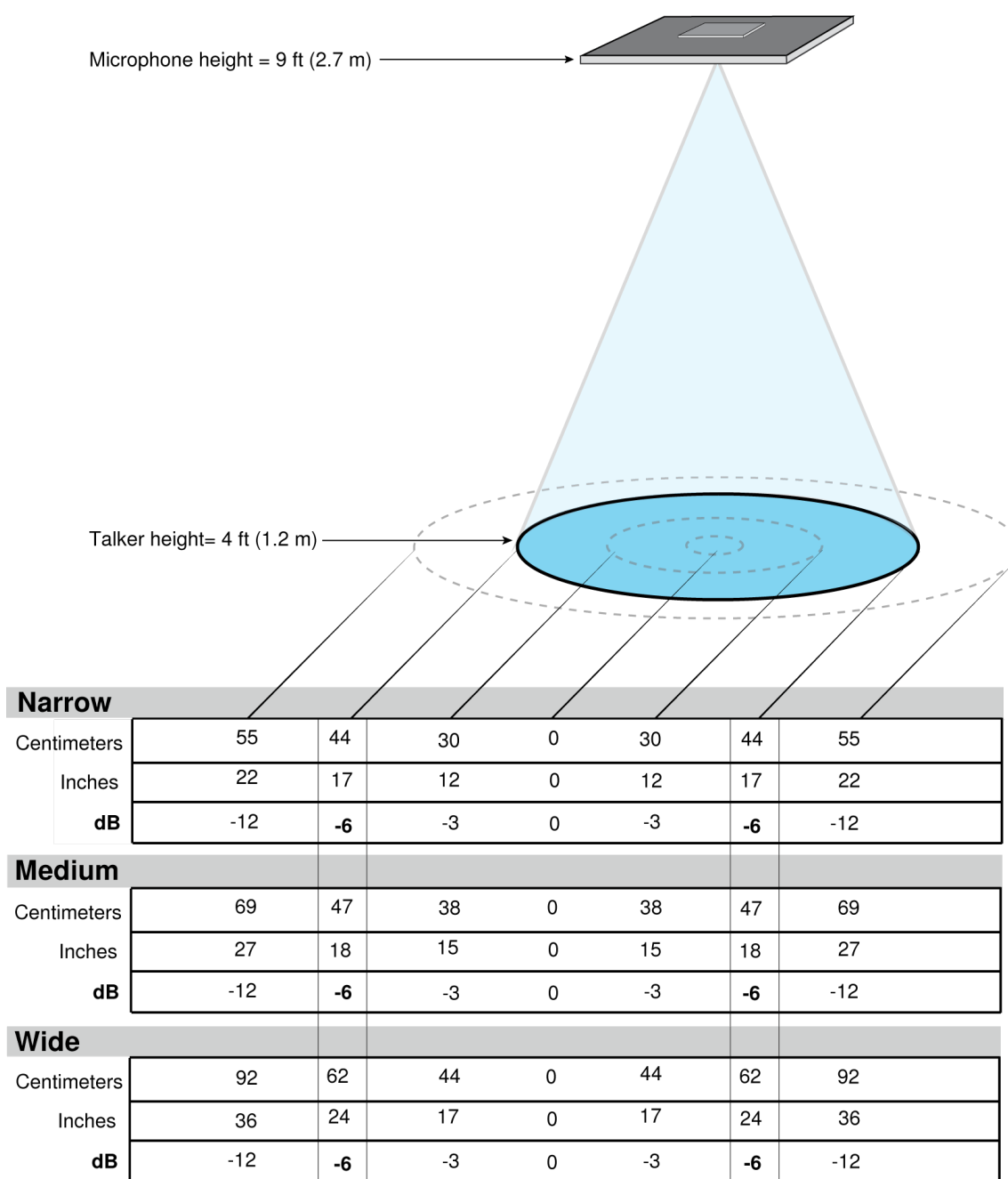

Accessories

Optional Accessories and Replacement Parts

Junction Box Accessory	A910-JB
MXA910W frame and grille assembly	RPM901

MXA910AL frame and grille assembly	RPM902
MXA910B frame and grille assembly	RPM903
MXA910W-60CM frame and grille assembly	RPM904
MXA910AL-60CM frame and grille assembly	RPM905
MXA910B-60CM frame and grille assembly	RPM906

Furnished Accessories

Rubber pad set	95A28365
Cable management clip	95A29877